

Dynalite Pro Series Front Brake Kits for Classic Chevrolet Impalas and Corvettes

Wilwood Engineering has just released six new Dynalite Pro Series disc brake upgrade kits for the classic year Impalas and mid-year Corvettes. Dynalite Pro Series brake kits provide a fully bolt-on performance upgrade for all models using the OE front spindles on all 1959-64 Impala, 1963-64 Corvette, 1965-70 Impala, and 1969-82 Corvette. Dynalite kits deliver positive disc brake stopping power and big brake styling for the street, with the top end performance and durability for the track.

High strength clamping force and positive stopping power are the trademark of the Wilwood forged billet alloy **Dynalite series 4 piston calipers**. Four stainless steel pistons provide fully balanced pad loading, along with the corrosion resistance and thermal retardant qualities of the stainless alloy that will keep your calipers cooler and running trouble free for many more miles down the road or track. Base model kits include either black anodized or gloss red sealed powder coat calipers. Polished calipers, or gloss black powder coated calipers, are also available by special request.

Friction is provided by BP-10 compound Wilwood “**Smart Pads**”. BP-10 is a unique metallic composite formula that provides quiet engagement and low dusting, but with the added temperature range and higher friction values of a semi-metallic compound pad. BP-10 runs clean and quiet on the street, with improved stopping power and fade resistance for tough roads or those fun days at the track. Optional race only pad compounds are also available.

The Pro Series kits can be purchased with either 11.00” or 12.19” diameter **ULHP** smooth face iron or **SRP** drilled and slotted E-coat rotors to maximize braking capacity and style with your wheel size and design. ULHP rotors are smooth face machined from premium grade carbon iron castings to provide true and precise running for the street, or any race sanctioning body that does not allow drilling and/or slotting on iron cast rotors. SRP performance rotors feature Wilwood’s signature directional drill and slot design with a protective E-coat finish. The drill and slot pattern adds race-tech styling and the venting qualities that preserve pad performance. The E-coat finish stays bonded and protects the rotors from rust on all areas that are not swept clean by the brake pads. Although 15” wheels are usually required, the 11.00” rotor kits will fit inside some properly back spaced disc brake application 14” wheels. 12.19” rotor kits will easily handle braking chores on most 16” and 17” wheel applications where the 12.19” rotor size is preferred. A wheel clearance chart is available for each kit to determine your wheel fitment capabilities.

Pro Series kits for these vehicle groups include forged and fully machined billet alloy hubs, with 1/2-20 grade 8 wheel studs, which mount to the OE spindle using tapered roller bearings and races. Every hub is “factory offset” designed to minimize hub track width change and reduce any possibility of tire to fender interference when changing from stock brakes. In addition to their strength, the forged billet hubs and modular design rotor mount plates provide a substantial weight savings over their steel and iron counterparts.

To complete the installation, precision machined and application specific brackets come along with premium grade hardware and alignment shims for a secure and accurate installation. DOT approved flexline kits, required to adapt Wilwood calipers to your chassis plumbing, are available separately by vehicle model in the application guide.

NOTE: To use any of these kits on a 1965-68 Corvette requires a spindle swap from any 1963-64 drum brake Corvette, or any 1969-82 disc brake Corvette along with the appropriate kit.

For more information contact: Wilwood Disc Brakes at (805) 388-1188 and request to speak with Erika Gordillo for marketing issues, or Andy Fritts for technical questions. Also, Wilwood’s website is accessible at www.wilwood.com or e-mail customerreply@wilwood.com



Dynalite Pro Series Front Kit Assembly
Download High Resolution Photo, [Click Here](#)



Dynalite Pro Series Complete Kit
Download High Resolution Photo, [Click Here](#)

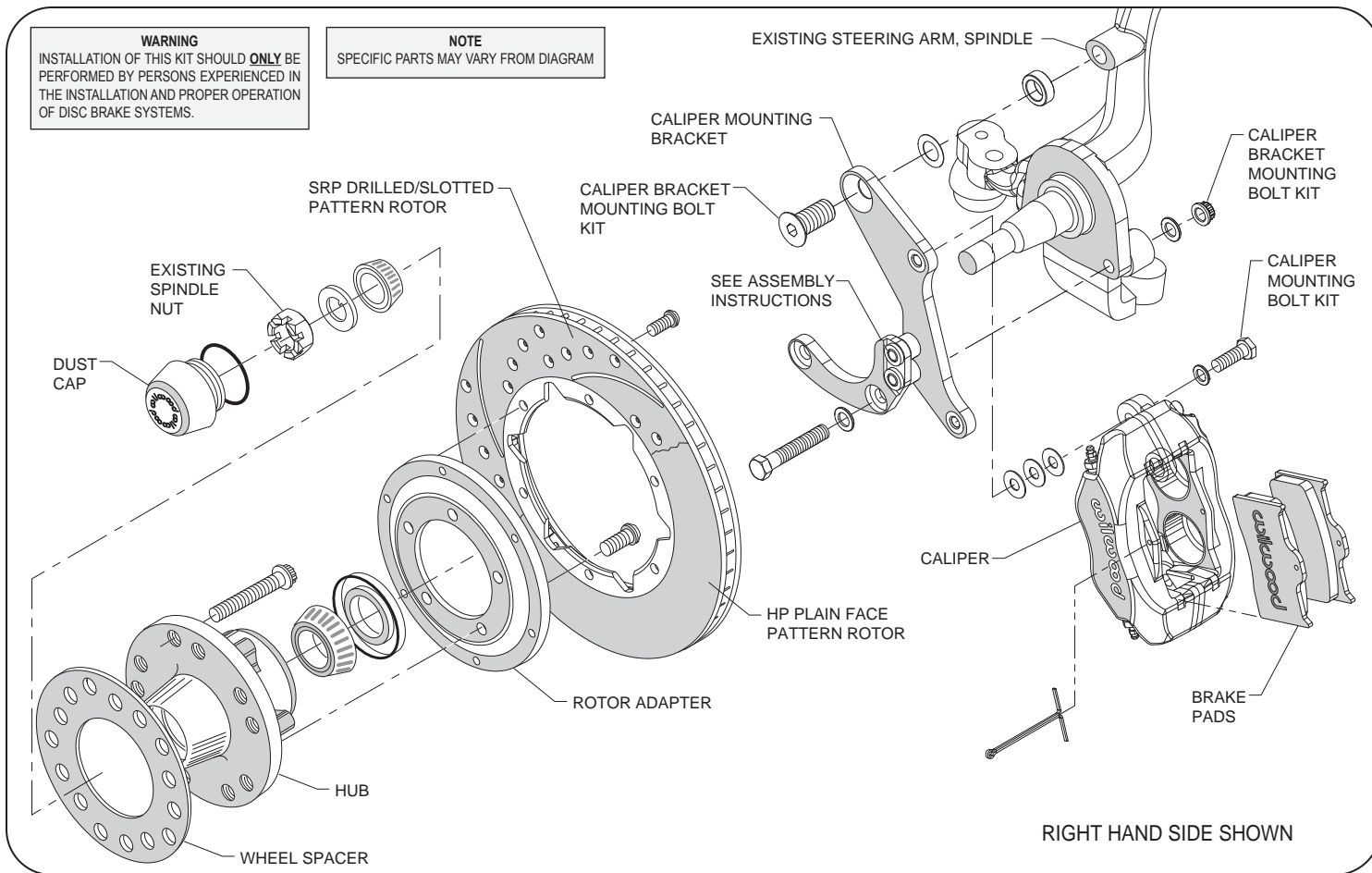

Typical Installation Diagram (11.00" Rotor Diameter Kit Shown)

ORDERING INFORMATION: 1959-64 IMPALA, 1963-64 CORVETTE DRUM BRAKE SPINDLES

<u>KIT NUMBER</u>	<u>CALIPER</u>	<u>ROTOR</u>	<u>PAD TYPE</u>	<u>FLEXLINE KIT</u>
140-12458	Black Anodized	11.00" ULHP	7112	220-7699
140-12458-D	Black Anodized	11.00" SRP, Drilled and Slotted	7112	220-7699
140-12458-DR	Red Powder Coat	11.00" SRP, Drilled and Slotted	7112	220-7699
140-12458-R	Red Powder Coat	11.00" ULHP	7112	220-7699
140-12459	Black Anodized	12.19" ULHP	7112	220-7699
140-12459-D	Black Anodized	12.19" SRP, Drilled and Slotted	7112	220-7699
140-12459-DR	Red Powder Coat	12.19" SRP, Drilled and Slotted	7112	220-7699
140-12459-R	Red Powder Coat	12.19" ULHP	7112	220-7699

ORDERING INFORMATION: 1965-68 IMPALA DRUM BRAKE SPINDLES

<u>KIT NUMBER</u>	<u>CALIPER</u>	<u>ROTOR</u>	<u>PAD TYPE</u>	<u>FLEXLINE KIT</u>
140-12021	Black Anodized	11.00" ULHP	7112	220-7699
140-12021-D	Black Anodized	11.00" SRP, Drilled and Slotted	7112	220-7699
140-12021-DR	Red Powder Coat	11.00" SRP, Drilled and Slotted	7112	220-7699
140-12021-R	Red Powder Coat	11.00" ULHP	7112	220-7699
140-12022	Black Anodized	12.19" ULHP	7112	220-7699
140-12022-D	Black Anodized	12.19" SRP, Drilled and Slotted	7112	220-7699
140-12022-DR	Red Powder Coat	12.19" SRP, Drilled and Slotted	7112	220-7699
140-12022-R	Red Powder Coat	12.19" ULHP	7112	220-7699

ORDERING INFORMATION: 1968-70 IMPALA DISC, 1969-70 IMPALA DRUM, 1969-82 CORVETTE

<u>KIT NUMBER</u>	<u>CALIPER</u>	<u>ROTOR</u>	<u>PAD TYPE</u>	<u>FLEXLINE KIT</u>
140-12040	Black Anodized	11.00" ULHP	7112	220-7699
140-12040-D	Black Anodized	11.00" SRP, Drilled and Slotted	7112	220-7699
140-12040-DR	Red Powder Coat	11.00" SRP, Drilled and Slotted	7112	220-7699
140-12040-R	Red Powder Coat	11.00" ULHP	7112	220-7699
140-12045	Black Anodized	12.19" ULHP	7112	220-7699
140-12045-D	Black Anodized	12.19" SRP, Drilled and Slotted	7112	220-7699
140-12045-DR	Red Powder Coat	12.19" SRP, Drilled and Slotted	7112	220-7699
140-12045-R	Red Powder Coat	12.19" ULHP	7112	220-7699