

STREET & TRACK DYNALITE / DYNAPRO MAZDA MIATA, NA, NB, ND BIG BRAKE KITS

Wilwood has engineered new performance brake kits for Miata enthusiasts. An oversized rotor is specced for more brake torque on NA/NB (1990-'05) and ND (2016-'24) platforms, clamped by Wilwood's workhorse forged aluminum four piston **Dynalite** street, or **Dynapro-ST** race calipers with **Thermlock™** pistons for big brake stopping power. Both are perfect complements to tire and suspension upgrades, and are fully compatible with your OE master cylinder and ABS.

KIT FEATURES:

- Complete bolt-on installation using factory hubs and spindles; no modifications are required
- Compatible with the factory master cylinder, rear brakes, ABS, and all electronic controls

CALIPERS: DYNALITE, DYNAPRO-ST

- Rigid forged billet aluminum four piston calipers with Type III Mil-Spec hard-anodized surfaces resist bore wear and abrasion
- Street kits available in gloss red or gloss black powder coat, or 26 additional colors (extra charges apply)

ROTORS: ULHP, SRP, GT SLOTTED

- Street kits available in 32-vane plain or **SRP** drilled and slotted faces in iron alloy; 11.75" x 0.81" (298mm x 21mm)
- Race kits feature a 40-vane full floating **Spec37** GT slotted rotor with Wilwood's **Lug-Drive** snap ring technology, eliminating mounting bolts; 11.75" x 0.81" (298mm x 21mm)
- Forged aluminum mounting hat reduces weight

BRAKE PADS: STREET or TRACK SPEC

- **BP-10** street-performance compound provides good response at low temperatures and resist fading as heat increases
- **BP-35** race-spec compound provides high friction with improved response as temps increase with a predictable linear feel
- Other compounds available for your application

INSTALLATION PARTS:

- Includes high-performance braided stainless Flexlines
- Forged aluminum caliper brackets and all premium-grade installation hardware also included



Dynalite Front Brake Kits - Street
P/N [140-17935-DR](#) (NA,NB)
P/N [140-17937-DR](#) (ND)

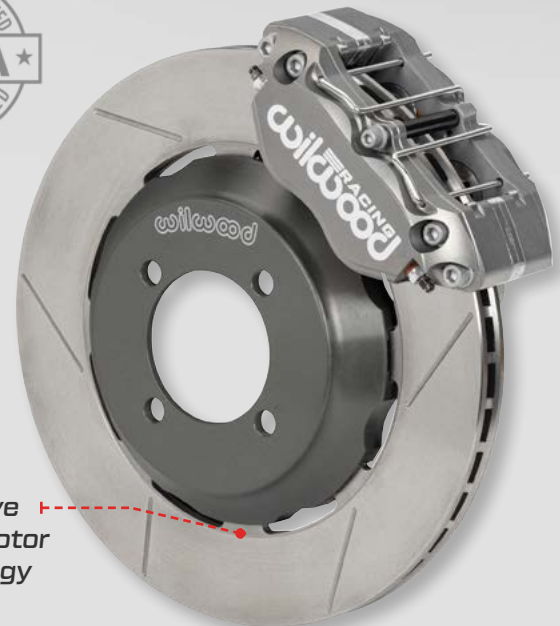

Lug-Drive
Floating Rotor
Technology

Dynapro Front Brake Kits - Race
P/N [140-17936](#) (NA,NB)
P/N [140-17938](#) (ND)

wilwood **DISC BRAKES**

MAZDA MX-5 MIATA

NA, NB, ND

DYNALITE/DYNAPRO 11.75" BIG BRAKE KITS STREET & TRACK



ULHP PLAIN
FACE ROTOR



SRP DRILLED &
SLOTTED ROTOR

Typical Installation Diagram

Miata NA, NB, ND
1990-2005, 2016-2024

WARNING
INSTALLATION OF THIS KIT SHOULD **ONLY** BE PERFORMED BY PERSONS EXPERIENCED IN THE INSTALLATION AND PROPER OPERATION OF DISC BRAKE SYSTEMS.

NOTE
SPECIFIC PARTS MAY VARY FROM DIAGRAM

STREET KIT

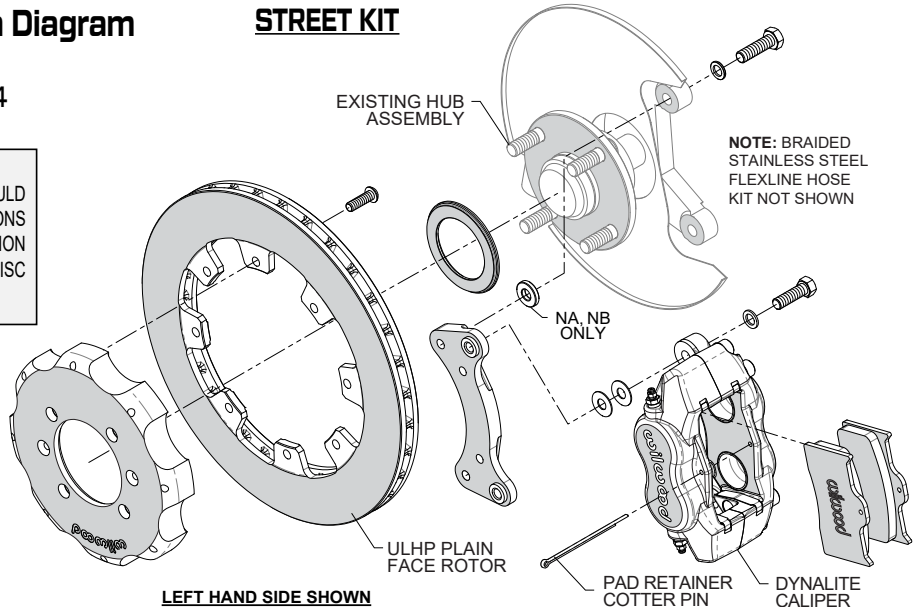

NOTE: BRAIDED STAINLESS STEEL FLEXLINE HOSE KIT NOT SHOWN

LEFT HAND SIDE SHOWN

Typical Installation Diagram

MIATA NA, NB, ND
1990-2005, 2016-2024

WARNING
INSTALLATION OF THIS KIT SHOULD **ONLY** BE PERFORMED BY PERSONS EXPERIENCED IN THE INSTALLATION AND PROPER OPERATION OF DISC BRAKE SYSTEMS.

NOTE
SPECIFIC PARTS MAY VARY FROM DIAGRAM

LUG-DRIVE RACE KIT

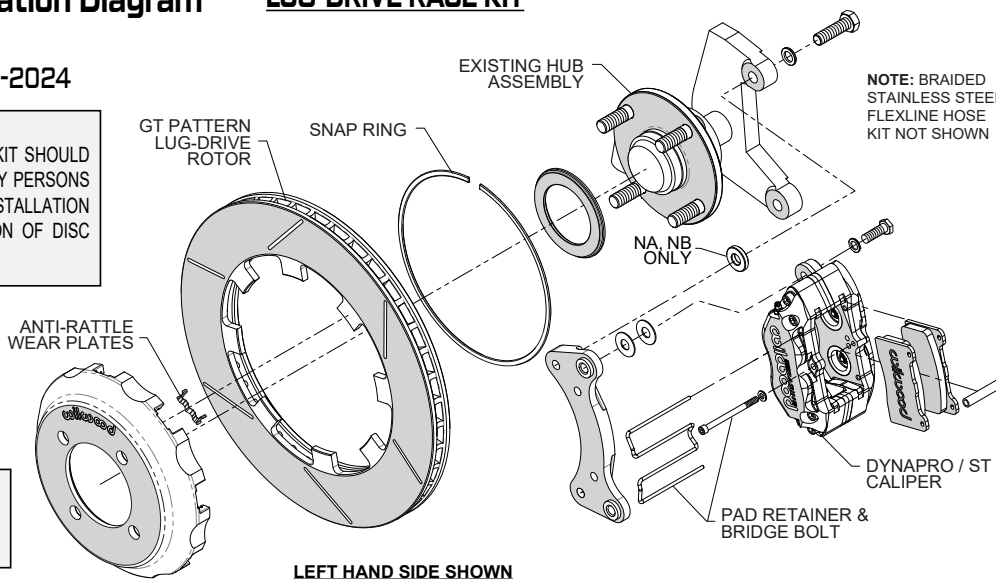

NOTE: BRAIDED STAINLESS STEEL FLEXLINE HOSE KIT NOT SHOWN

LEFT HAND SIDE SHOWN



GT SLOTTED **Spec37**
LUG-DRIVE ROTOR

ORDERING INFORMATION: PH: 805.388.1188 • FAX: 805.388.4938 • wilwood.com • info@wilwood.com

BLACK	RED	AND	DESCRIPTION	CALIPER TYPE	ROTOR TYPE	ROTOR SIZE
140-17935	140-17935-R		Street Kit, Dynalite Front, MX-5, NA,NB (1990-05)	Dynalite, FDLI 4 Piston	ULHD Plain Face	11.75" x 0.81"
140-17935-D	140-17935-DR		Street Kit, Dynalite Front, MX-5, NA,NB (1990-05)	Dynalite, FDLI 4 Piston	SRP Drilled & Slotted	11.75" x 0.81"
140-17937	140-17937-R		Street Kit, Dynalite Front, MX-5, ND (2016-24)	Dynalite, FDLI 4 Piston	ULHD Plain Face	11.75" x 0.81"
140-17937-D	140-17937-DR		Street Kit, Dynalite Front, MX-5, ND (2016-24)	Dynalite, FDLI 4 Piston	SRP Drilled & Slotted	11.75" x 0.81"
		140-17936	Race Kit, Dynapro-ST Front, MX-5, NA,NB (1990-05)	Dynapro-ST, DP 4 Piston	GT Slotted Spec37 Lug-Drive	11.75" x 0.81"
		140-17938	Race Kit, Dynapro-ST Front, MX-5, ND (2016-24)	Dynapro-ST, DP 4 Piston	GT Slotted Spec37 Lug-Drive	11.75" x 0.81"