

- ✓ IMCA officially approved GM Metric OEM replacement caliper (P/N: 120-16101)
- ✓ Meets all IMCA brake rules for Modifieds, Stock Cars, Hobby Stocks, Northern & Southern SportMods
- ✓ New casting purpose-built for racing (not a remanufactured part)
- ✓ 2.50" stainless steel piston
- ✓ Equipped with high-temp square section seals for ultimate pedal-feel and resistance to excessive piston knock-back
- ✓ Dual symmetrical bleeders eliminate the need for carrying multiple spares as calipers may be right or left mounted



**APPROVED
BRAKE
CALIPER**



HARDENED SLIDE PINS

- High-strength alloy steel
- Black oxide coat finish
- Each caliper requires two slide pins
- Four-pack sold separately (P/N: 230-0619)



CALIPER FITTING

Sold separately
P/N: 220-17471

ORDERING INFO: PH: 805.388.1188 • FAX: 805.388.4938 • wilwood.com • info@wilwood.com

PART NUMBER	DESCRIPTION	PISTON BORE SIZE	FINISH
120-9333	GM Metric Cast Iron D-154 Caliper	2.00" (50.8 mm)	Black E-Coat
120-16101	GM Metric Cast Iron D-154 Caliper IMCA LEGAL	2.50" (63.5 mm)	Black E-Coat
120-8924	GM Metric Cast Iron D-154 Caliper	2.75" (69.9 mm)	Black E-Coat
230-0619	Bolt Kit - Caliper Slide Pin 4-pack		Black Oxide Coated
220-17471	Caliper Inlet Fitting -3 TO 10mm-1.5 with a crush washer		



GM Metric Iron Caliper, Dimensional Characteristics

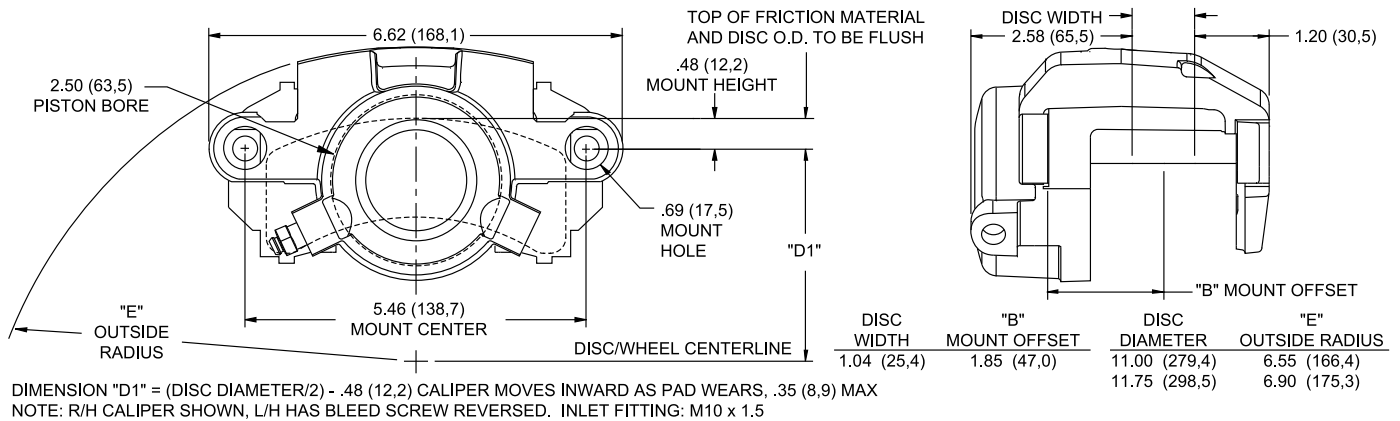

GM Metric Iron Caliper, Type D154 Brake Pad Dimensions and Ordering Information

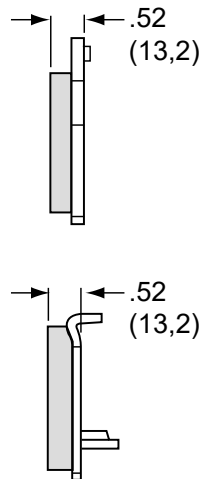
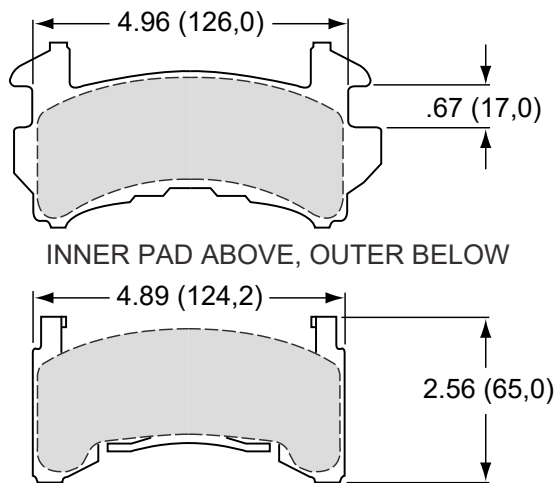

PART NUMBER	COMPOUND
150-10-D0154K	BP-10
150-20-D154K	BP-20
150-28-D154K	BP-28
150-30-D154K	BP-30
150-35-D154K	BP-35
150-40-D154K	BP-40
150-45-D154K	BP-45

GM Metric Iron Caliper, User Serviceable Components and Ordering Information

CALIPER PART NUMBER	PISTON	O-RING	BLEED SCREW
120-16101	200-11793	130-12084	220-8932