



# W6AR FRONT BIG BRAKE KITS

## 1999 - 2006 BMW E46

### Models Covered:

- 1999 323i/328i Sedan Only, E46
- 2000 323i/328i All
- 2001-2005 325i/330i Except xi
- 2001-2005 320i Sedan (Canada)
- 2006 325i/330i Coupe and Convertible Except xi

### Kit Features:

- Extreme performance upgrade for aggressive street / track combination vehicles and dedicated competition machines.
- Engineered to maximize braking capacity inside custom and race offset wheels.
- Simple bolt-on installation with no modifications required.
- Fully compatible with ABS and OE master cylinder output.

### Component Features:

#### W6AR Forged Billet Radial Mount Calipers

- Competition proven and fully detail machined forged billet body demonstrates superior strength and resistance to deflection and separation under high load.
- Differential bore six piston design generates big brake clamping force with balanced pad loading for even wear in all sustained high heat, high load conditions.
- W6AR calipers use stainless pistons to resist corrosion and reduce heat transfer from the pads.
- Spring loaded SRS bridge plates dampen noise and engagement harmonics while protecting the caliper bridge from wear by pad gouging.
- High temperature, fluid resistant high gloss black finish is standard, with red available as an option.



BMW Big Brake Front Kit with  
GT Rotor and Red Caliper

#### GT or SRP Directional Vane 14.00" Rotors

- Directional vane rotors provide the highest degree of cooling efficiency with increased surface area and improved air circulation between the rotor faces.
- GT series rotors are competition prepared with asymmetrical face slotting, full detail machining, and individual dynamic balancing to deliver maximum durability and thermal stability in sustained high heat temperature conditions with smooth operation at all speeds.
- Optional SRP directional drilled and slotted rotors enhance pad performance with consistent response by cleaning and venting gasses, dust, and burnt pad material. A proprietary black e-coat finish is applied to resist corrosion.

#### Forged Aluminum GT Mounting Hats

- Forged aluminum rotor mount hats help reduce weight with the strength to handle the exceptional brake torque delivered by the W6AR caliper.
- Black anodized finish resists corrosion while adding to the aggressive competition look inside the wheel.

#### Wilwood BP-10 "Smart Pads"

- All kits include BP-10 metallic-composite compound "Smart Pads". BP-10 delivers the increased friction; higher fade resistance, and longer wear of an entry-level track pad, with virtually noise and dust free performance for the street.
- Optional race-only compounds can be ordered to suit the braking requirements at all levels of severe duty and sustained high heat competition.

#### Radial Mounting Hardware and Plumbing

- Radial mounting provides secure attachment directly to the OE mount with two planes of adjustment for precise alignment over the rotor. Brackets, premium grade fasteners, and alignment shims are included in each kit.
- Stainless steel braided competition flex line kits are necessary to connect the Wilwood calipers to the brake system and must be ordered separately.

**WARNING**

INSTALLATION OF THIS KIT SHOULD **ONLY** BE PERFORMED BY PERSONS EXPERIENCED IN THE INSTALLATION AND PROPER OPERATION OF DISC BRAKE SYSTEMS.

**NOTE**

SPECIFIC PARTS MAY VARY FROM DIAGRAM

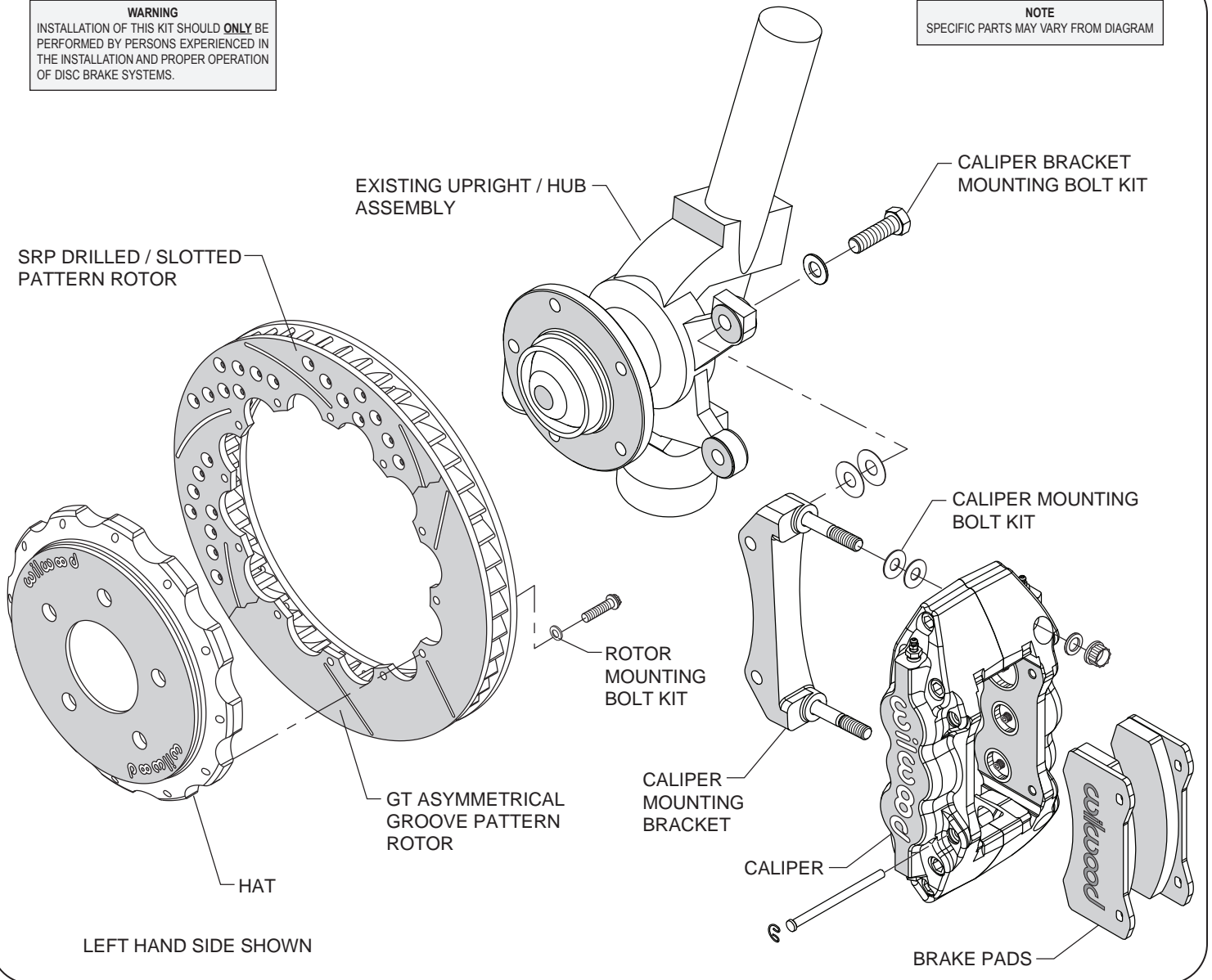

**Typical Installation Diagram**

**ORDERING INFORMATION:**

**PART NUMBER**

**DESCRIPTION**

140-11974	Front Kit, BMW E46, W6AR Caliper, 14.00" GT Rotor
140-11974-D	Front Kit, BMW E46, W6AR Caliper, 14.00" SRP Drilled and Slotted Rotor
140-11974-DR	Front Kit, BMW E46, W6AR Caliper, 14.00" SRP Drilled and Slotted Rotor, Red Caliper
140-11974-R	Front Kit, BMW E46, W6AR Caliper, 14.00" GT Rotor, Red Caliper