

INSTALLATION INSTRUCTIONS FOR WIDE 5 ZERO OFFSET FLOATER PLATE • P/N 300-14294

WARNING

IT IS THE RESPONSIBILITY OF THE PERSON INSTALLING ANY BRAKE COMPONENT OR KIT TO DETERMINE THE SUITABILITY OF THE COMPONENT OR KIT FOR THAT PARTICULAR APPLICATION. IF YOU ARE NOT SURE HOW TO SAFELY USE THIS BRAKE COMPONENT OR KIT, YOU SHOULD NOT INSTALL OR USE IT. DO NOT ASSUME ANYTHING. IMPROPERLY INSTALLED OR MAINTAINED BRAKES ARE DANGEROUS. IF YOU ARE NOT SURE, GET HELP OR RETURN THE PRODUCT. YOU MAY OBTAIN ADDITIONAL INFORMATION AND TECHNICAL SUPPORT BY CALLING WILWOOD AT (805) 388-1188, OR VISIT OUR WEB SITE AT WWW.WILWOOD.COM. USE OF WILWOOD TECHNICAL SUPPORT DOES NOT GUARANTEE PROPER INSTALLATION. **YOU**, OR THE PERSON WHO DOES THE INSTALLATION MUST KNOW HOW TO PROPERLY USE THIS PRODUCT. IT IS NOT POSSIBLE OVER THE PHONE TO UNDERSTAND OR FORESEE ALL THE ISSUES THAT MIGHT ARISE IN YOUR INSTALLATION.

RACING EQUIPMENT AND BRAKES MUST BE MAINTAINED AND SHOULD BE CHECKED REGULARLY FOR FATIGUE, DAMAGE, AND WEAR.

Assembly Instructions:

Orient the rotor (sold separately) and the floater plate as shown in Figure 1 and Photo 1. Attach rotor to plate using bolts (P/N 230-6739*), washers (P/N 240-10191*) and t-nuts (P/N 300-12739*), Figure 1. Follow additional instructions included with the bolt kit. Using an alternating sequence, apply red *Loctite*® 271 to the bolt threads and torque to 220 **in-lbs**. Safety wire bolts using standard 0.032 inch diameter stainless steel safety wire as shown in Figure 2. Refer to Wilwood's data sheet DS-386 (available at www.wilwood.com/Pdf/DataSheets/ds386.pdf) for complete safety wire installation instructions.

Attach the plate/rotor assembly to the wide 5 hub using bolts (P/N 230-0318**) and washers (P/N 240-10191**) as shown in Figure 1. Apply red *Loctite*® 271 to bolt threads and torque to 25 ft-lbs.

Notes:

(*) Included in plate to rotor mounting bolt kit, P/N 230-10483 (sold separately)

(**) Included in plate to wide 5 mounting bolt kit, P/N 230-8390 (sold separately)

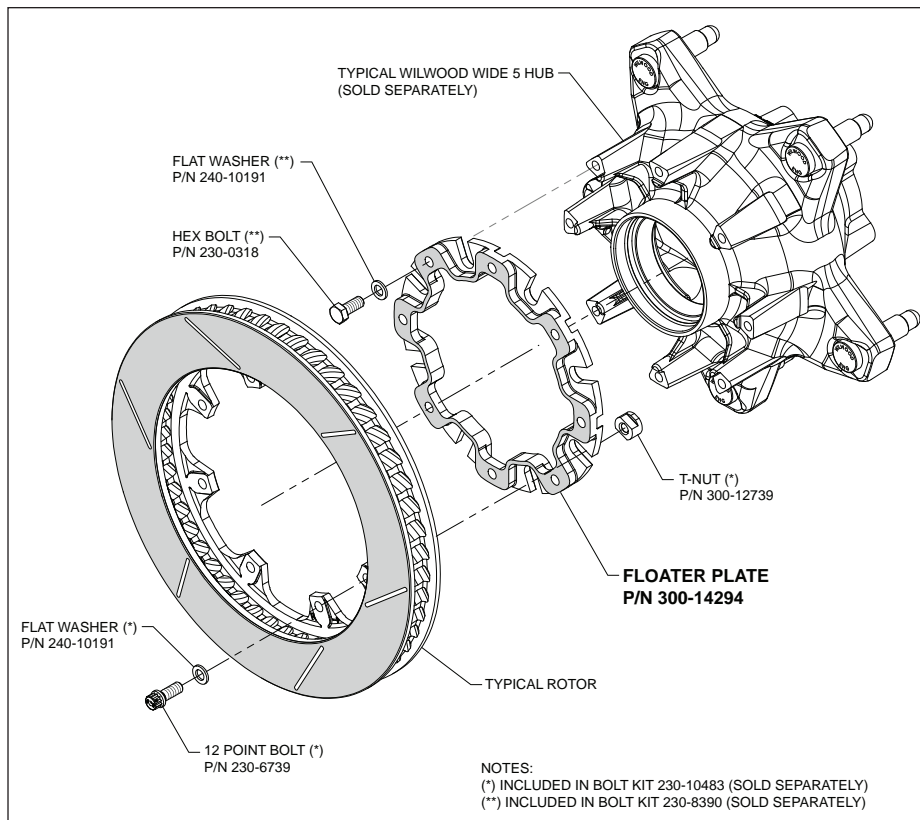

Figure 1. Typical Rotor Plate Installation



**Photo 1. Plate Mounted to Rotor
(GT rotor shown)**

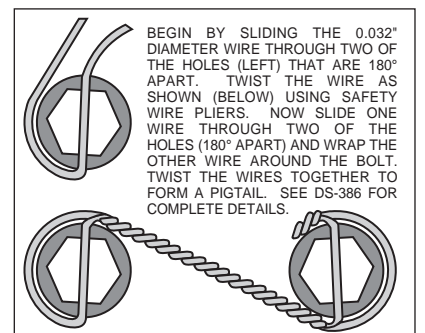

Figure 2. Safety Wire Diagram