

ASSEMBLY INSTRUCTIONS
FOR
DYNAPRO BIG BRAKE FRONT HAT KIT, 12.19" DIAMETER VENTED ROTOR

1995-1999 MITSUBISHI ECLIPSE GENERATION II

PART NUMBER GROUP

140-8292

**DISC BRAKES SHOULD ONLY BE INSTALLED BY SOMEONE
EXPERIENCED AND COMPETENT IN THE INSTALLATION AND
MAINTENANCE OF DISC BRAKES
READ ALL WARNINGS**

WARNING

IT IS THE RESPONSIBILITY OF THE PERSON INSTALLING ANY BRAKE COMPONENT OR KIT TO DETERMINE THE SUITABILITY OF THE COMPONENT OR KIT FOR THAT PARTICULAR APPLICATION. IF YOU ARE NOT SURE HOW TO SAFELY USE THIS BRAKE COMPONENT OR KIT, YOU SHOULD NOT INSTALL OR USE IT. DO NOT ASSUME ANYTHING. IMPROPERLY INSTALLED OR MAINTAINED BRAKES ARE DANGEROUS. IF YOU ARE NOT SURE, GET HELP OR RETURN THE PRODUCT. YOU MAY OBTAIN ADDITIONAL INFORMATION AND TECHNICAL SUPPORT BY CALLING WILWOOD AT (805) 388-1188, OR VISIT OUR WEB SITE AT WWW.WILWOOD.COM. USE OF WILWOOD TECHNICAL SUPPORT DOES NOT GUARANTEE PROPER INSTALLATION. **YOU**, OR THE PERSON WHO DOES THE INSTALLATION MUST KNOW HOW TO PROPERLY USE THIS PRODUCT. IT IS NOT POSSIBLE OVER THE PHONE TO UNDERSTAND OR FORESEE ALL THE ISSUES THAT MIGHT ARISE IN YOUR INSTALLATION.

RACING EQUIPMENT AND BRAKES MUST BE MAINTAINED AND SHOULD BE CHECKED REGULARLY FOR FATIGUE, DAMAGE, AND WEAR.



Need Additional Information?
Use Your SmartPhone and
Jump to Our Technical Tips
Section on Our Web Site.



WARNING

**DO NOT OPERATE ANY VEHICLE ON UNTESTED BRAKES!
SEE MINIMUM TEST PROCEDURE WITHIN**

ALWAYS UTILIZE SAFETY RESTRAINT SYSTEMS AND ALL OTHER AVAILABLE SAFETY EQUIPMENT WHILE OPERATING THE VEHICLE

IMPORTANT • READ THE DISCLAIMER OF WARRANTY INCLUDED IN THE KIT

NOTE: Some cleaners may stain or remove the finish on brake system components. Test the cleaner on a hidden portion of the component before general use.

Important Notice - Read This First

Before any tear-down or disassembly begins, review the following information:

- Review the wheel clearance diagram (figure 2, page 3) to verify that there is adequate clearance with the wheels you will be using with the installation.
- Front brake kits do not include flex lines. OEM brake lines will not adapt to Wilwood calipers. Check the assembly instructions, or associated components section for brake line recommendations before assembly. In addition, Wilwood offers an extensive listing of brake lines and fittings on our web site: www.wilwood.com.
- Due to OEM production differences and other variations from vehicle to vehicle, the fastener hardware and other components in this kit may not be suitable for a specific application or vehicle.
- It is the responsibility of the purchaser and installer of this kit to verify suitability / fitment of all components and ensure all fasteners and hardware achieve complete and proper engagement. Improper or inadequate engagement can lead to component failure.

Exploded Assembly Diagram

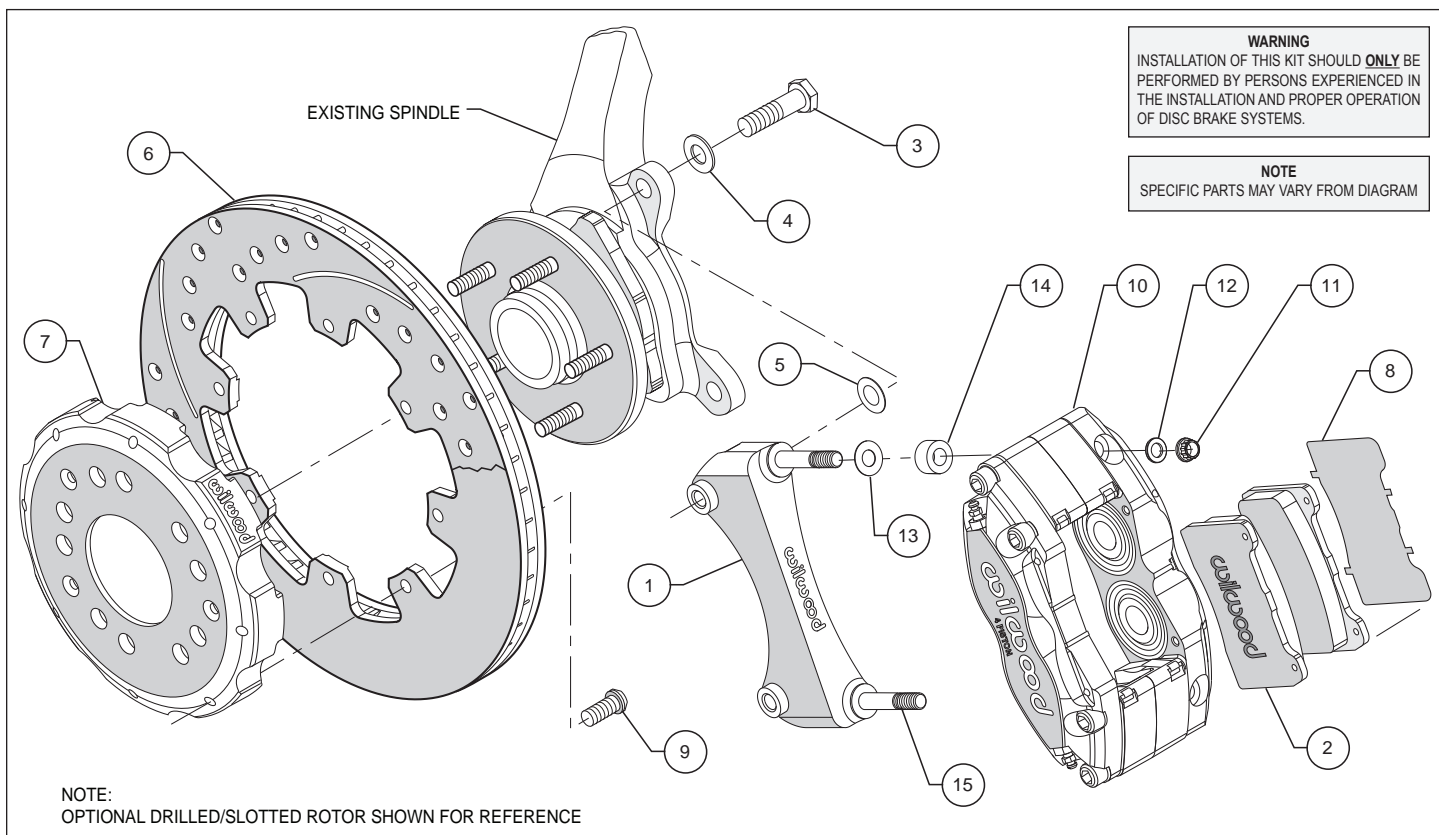

Figure 1. Typical Installation Configuration

Parts List

ITEM NO.	PART NO.	DESCRIPTION	QTY
1	250-8321	Bracket, Caliper Mounting	2
2	15Q-7268K	Pad, PolyMatrix, Axle Set	1
3	230-9897	Bolt, 7/16-20 x 1.25 Long, Hex Head	4
4	240-11101	Washer, .453 I.D. x .750 O.D. x .063 Thick	4
5	240-5680	Shim, .020 Thick	8
6	160-5843	Rotor, .81" Thk x 12.19" Dia, 8 x 7.00" Bolt Circle	2
6A	160-7103/04	Rotor, Drilled and Slotted	2
7	170-8320	Hat	2
8	300-12177	Anti-Squeal Shims	4
9	230-11935	Bolt, 5/16-18 x 1.00 Long, Button Head Torx	16
10	120-7378	Caliper, DynaPro	2
11	230-9183	Nut, 3/8-24 Self-Locking, 12 Point	4
12	240-10190	Washer, .391 I.D. x .625 O.D. x .063 Thick	4
13	240-10306	Shim, .016 Thick	12
14	300-7352	Spacer, .425 Long	4
15	230-9079	Stud, 3/8-16 x 3/8-24 x 3.15 Long (pre-installed in bracket)	4

NOTES:

Part Number 230-12177 Rotor Bolt Kit, includes part number 230-11935

Part Number 250-8322 Caliper Bracket Mounting Bolt Kit, includes P/N's 230-9183, 230-9079, 240-10306, 240-10190, 250-8321 & 300-7352

Part Number 230-8391 Spindle Bracket Mounting Bolt Kit, includes P/N's 230-9897, 240-0476, 240-11101 & 240-5680

Item 6A is an optional item and is included with the "-D" kits. Add "-D" to end of part number when ordering.

Wilwood offers an optional Braided Stainless Steel Hose Kit. Order part number 220-8293 (not included in kit)

General Information, Disassembly, and Assembly Instructions

Installation of this kit should **ONLY** be performed by persons experienced in the installation and proper operation of disc brake systems. Before installation begins, please read the complete procedure thoroughly to familiarize yourself with the process, and double check the following items to ensure a trouble-free installation.

- Make sure this is the correct kit to match the exact make and model year of the vehicle's spindle (i.e., brackets for a 1994 Mitsubishi may not fit a 1999 Mitsubishi spindle).
- Verify the hat stud pattern in this kit matches the stud pattern of the vehicle's hubs (see note below).
- Verify your wheel clearance using Figure 2.
- Inspect the package contents against the parts list to ensure that all components and hardware are included.

Disassembly

- Disassemble the original equipment front brakes:

Raise the front wheels off the ground and support the front suspension according to the vehicle manufacturer's instructions.

Remove the wheel. Remove the two bolts that hold the stock caliper mounting bracket to the spindle. Lift off the bracket and stock caliper as one unit, then slide off the stock hat and rotor assembly. On some models you may have to unbolt the stock caliper from the caliper bracket before removal.

- Thoroughly clean the spindles.

Assembly Instructions (numbers in parenthesis refer to the part list/diagram on the preceding page): **CAUTION:** All mounting bolts must fully engage insert nuts. Be sure to check that all bolts are either flush or protruding through flanged side of insert nut after shimming.

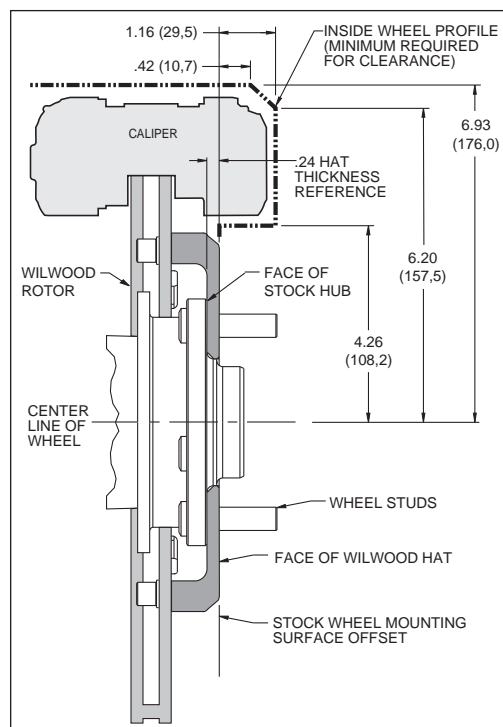

Figure 2. Wheel Clearance Diagram

Assembly Instructions (Continued)

- The caliper mounting bracket assembly (1) should be installed first with clean, dry threads on the mounting bolts. Install the bracket from the front side of the spindle by sliding bolts (3) through washer (4), as shown in Figure 1. Place shim (5) between the bracket and the front side of the spindle, Figure 1. The bracket must tighten squarely against the side of the spindle body. Inspect for interference from casting irregularities, machining ridges, burrs, etc. Use one thin shim (5) between the spacer and spindle during initial trial fitting.
- With the larger I.D. side of the rotor (6) facing away from the hat (7), attach rotor (6) to hat (7) using bolts (9) as shown in Figure 1. Using an alternating sequence, remove bolts (9) one at a time, apply red *Loctite*® 271 to the threads, and torque to 25 ft-lb. **NOTE:** *The rotor hat included in this kit is a multiple use part and has two 5 x 4.50" bolt circles. For correct use in this application, use the bolt circle with the smaller diameter (.484") stud holes. For further reference, check the inside face of hat assembly, one of the smaller diameter stud holes will have a circular reference mark engraved around its circumference. Do not use the larger diameter stud holes, as rotor and hat will not center correctly on hub.*
- Slide the rotor/hat assembly onto the axle hub. Install three lug nuts (finger tighten) to keep the rotor/hat assembly in place while continuing with the installation.
- NOTE:** *Please reference the caution statement at the beginning of the assembly instructions.* Install one shim (13) and spacer (14) over each pre-installed stud (15) on the radial mount bracket (1). Slide the caliper (10) in place over the studs and rotors and install the washer (12) and lock nut (11) to hold the caliper in place. Snug the lock nuts (11) and check that the rotor (6) is centered in the caliper (10). Add or subtract .020" shims (4) as necessary between the bracket (1) and the spindle to center the caliper (10).
- Remove the caliper quick-clip pad retainer from the caliper. Remove the protective material from the adhesive side of the anti-squeal shims (8) and place against the backing plate side of the brake pads (2) utilizing the contour of the backing plate as a guide. Secure material to backing plate by bending the four tabs over the edge of the backing plate. Slide the brake pads (2) with the shims into place. They should install easily without interference. Check that the outside radius of the brake pad is aligned with the outside diameter radius of the rotor face. Add or subtract shims (13) between the caliper and mount bracket to gain the proper alignment. Reinstall the quick-clip pad retainer.
- Remove the lug nuts that were holding the hat in place. Install the wheel. Check to see that the wheel rotates freely without interference.
- Once all clearances have been checked, remove the wheel, caliper, hat, and rotor from the spindle and hub. Secure the caliper mounting bracket (1) to the spindle using red *Loctite*® 271. Torque the bolts to 60 ft-lbs. Reinstall the hat and rotor assembly and again use several lug nuts to hold it in place. Lubricate caliper mounting studs and nuts with lightweight oil, reinstall the caliper, torque the caliper nuts (11) to 28 ft-lb.
- NOTE:** *OEM rubber brake hoses generally cannot be adapted to Wilwood calipers. The caliper inlet fitting is a 1/8-27 NPT. The preferred method is to use steel adapter fittings at the caliper, either straight, 45 or 90 degree and enough steel braided line to allow for full suspension travel and turning radius, lock to lock. Carefully route lines to prevent contact with moving suspension, brake or wheel components.* Wilwood hose kits are designed for use in many different vehicle applications and it is the installer's responsibility to properly route and ensure adequate clearance and retention for brake hose components. Wilwood offers a hose kit, P/N 220-8293, which includes hoses, fittings, etc., all in one package for this application.
- Specified brake hose kits may not work with all Years, Makes and Models of vehicle that this brake kit is applicable to, due to possible OEM manufacturing changes during a production vehicle's life. It is the installer's responsibility to ensure that all fittings and hoses are the correct size and length, to ensure proper sealing and that they will not be subject to crimping, strain and abrasion from vibration or interference with suspension components, brake rotor or wheel.
- In absence of specific instructions for brake line routing, the installer must use his best professional judgment on correct routing and retention of lines to ensure safe operation. Test vehicle brake system per the 'minimum test' procedure stated within this document before driving. After road testing, inspect for leaks and interference. Initially after install and testing, perform frequent checks of the vehicle brake system and lines before driving, to confirm that there is no undue wear or interference not apparent from the initial test. Afterwards, perform periodic inspections for function, leaks and wear in a interval relative to the usage of vehicle.
- Bleed the brake system. Reference the general information and recommendations on page 5 for proper bleeding instructions.
- Remove the lug nuts that were used to hold the rotor/hat assembly in place during caliper installation. Install the wheel and lug nuts, torque to OEM specifications.
- Repeat the entire procedure for the other wheel.

Additional Information and Recommendations

- Please read the following concerning balancing the brake bias on 4 wheel disc vehicles.

This brake kit can be operated using the stock OEM master cylinder. However, as with most suspension and tire modifications (from OEM specifications), changing the brakes may alter the front to rear brake bias. Rear brakes should not lock up before the front. Brake system evaluation and tests should be performed by persons experienced in the installation and proper operation of brake systems. Evaluation and tests should be performed under controlled conditions. Start by making several stops from low speeds then gradually work up to higher speeds. Always utilize safety restraint systems while operating vehicle.

Use a Wilwood adjustable proportioning valve if necessary to achieve proper brake balance, or

Use a Wilwood brake pedal/balance bar assembly with dual master cylinders (requires custom mounting as used in fabricated chassis race cars). A balance bar brake system permits incremental front to rear brake pressure adjustments.

- For optimum performance, fill and bleed the new system with Wilwood Hi-Temp^o 570 grade fluid or EXP 600 Plus. For severe braking or sustained high heat operation, use Wilwood EXP 600 Plus Racing Brake Fluid. Used fluid must be completely flushed from the system to prevent contamination. **NOTE:** *Silicone DOT 5 brake fluid is **NOT** recommended for racing or performance driving.*

- To properly bleed the brake system, begin with the caliper farthest from the master cylinder. Bleed the outboard bleed screw first, then the inboard. Repeat the procedure until all calipers in the system are bled, ending with the caliper closest to the master cylinder. **NOTE:** *When using a new master cylinder, it is important to bench bleed the master cylinder first.*

- If the master cylinder is mounted lower than the disc brake calipers, some fluid flowback to the master cylinder reservoir may occur, creating a vacuum effect that retracts the caliper pistons into the housing. This will cause the pedal to go to the floor on the first stroke until it has “pumped up” and moved all the pistons out against the pad again. A Wilwood in-line two pound residual pressure valve, installed near the master cylinder will stop the fluid flowback and keep the pedal firm and responsive.

- Test the brake pedal. It should be firm, not spongy and stop at least 1 inch from the floor under heavy load.

If the brake pedal is spongy, bleed the system again.

If the brake pedal is initially firm, but then sinks to the floor, check the system for fluid leaks. Correct the leaks (if applicable) and then bleed the system again.

If the brake pedal goes to the floor and continued bleeding of the system does not correct the problem, a master cylinder with increased capacity (larger bore diameter) will be required. Wilwood offers various lightweight master cylinders with large fluid displacement capacities.

- NOTE:** *With the installation of after market disc brakes, the wheel track may change depending on the application. Check your wheel offset before final assembly.*

- On some models of disc brake spindles there are “ears” where the OEM calipers were mounted and these “ears” interfere with the assembly of the Wilwood disc brake kit. If it becomes necessary to remove these “ears”, remove as little as possible being careful not to cut away any of the mounting holes that may be required to bolt on the caliper mounting bracket.

- If after following the instructions, you still have difficulty in assembling or bleeding your Wilwood disc brakes, consult your local chassis builder, or retailer where the kit was purchased for further assistance.

Brake Testing and Pad Bedding

WARNING • DO NOT DRIVE ON UNTESTED BRAKES BRAKES MUST BE TESTED AFTER INSTALLATION OR MAINTENANCE MINIMUM TEST PROCEDURE

- Make sure pedal is firm: Hold firm pressure on pedal for several minutes, it should remain in position without sinking. If pedal sinks toward floor, check system for fluid leaks. DO NOT drive vehicle if pedal does not stay firm or can be pushed to the floor with normal pressure.
- At very low speed (2-5 mph) apply brakes hard several times while turning steering from full left to full right, repeat several times. Remove the wheels and check that components are not touching, rubbing, or leaking.
- Carefully examine all brake components, brake lines, and fittings for leaks and interference.
- Make sure there is no interference with wheels or suspension components.
- Drive vehicle at low speed (15-20 mph) making moderate and hard stops. Brakes should feel normal and positive. Again check for leaks and interference.
- Always test vehicle in a safe place where there is no danger to (or from) other people or vehicles.
- Always wear seat belts and make use of all safety equipment.

PAD BEDDING PROCEDURE:

• Pump brakes at low speed to assure proper operation. On the race track, or other safe location, make a series of hard stops until some brake fade is experienced. Allow brakes to cool while driving at moderate speed to avoid use of the brakes. This process will properly burnish the brake pads, offering maximum performance.

Associated Components

<u>PART NO.</u>	<u>DESCRIPTION</u>
260-1874	Wilwood Residual Pressure Valve (2 lb for disc brakes)
260-1876	Wilwood Residual Pressure Valve (10 lb for drum brakes)
260-8419	Wilwood Proportioning Valve
290-0632	Wilwood Racing Brake Fluid (Hi-Temp° 570) (12 oz)
290-6209	Wilwood Racing Brake Fluid (EXP 600 Plus) (16.9 oz)
340-1285	Wilwood Floor Mount Brake Pedal (with balance bar)
340-1287	Wilwood Swing Mount Brake Pedal (with balance bar)
260-6764	Wilwood 3/4 inch High Volume Aluminum Master Cylinder
260-6765	Wilwood 7/8 inch High Volume Aluminum Master Cylinder
260-6766	Wilwood 1 inch High Volume Aluminum Master Cylinder
260-8555	Wilwood 1 inch Aluminum Tandem Chamber Master Cylinder
260-8556	Wilwood 1-1/8 inch Aluminum Tandem Chamber Master Cylinder
270-2016	Quick Release Steering Hub (3/4 inch shaft)
270-2017	Quick Release Steering Hub (5/8 inch shaft)
220-3509	Fitting, Straight (1/8-27 NPT to -3)
220-6412	Fitting, 45° Elbow (1/8-27 NPT to -3)
220-6413	Fitting, Adaptor Tubing (10mm to -3)
220-6415	Fitting, 90° Elbow (1/8-27 NPT to -3)
220-8339	Stainless Steel Braided Flexline Kit