



CADILLAC • 1957-1960 DYNALITE CLASSIC FRONT DISC BRAKE KITS

Classic Series front brake kits for 1957 to 1960 Cadillac's provide an affordable and easy bolt-on solution for upgrading from Original Equipment (OE) drum brakes on these classic era cars.



Kit Features

- Forged Dynalite four piston aluminum calipers in red powder coat or black anodized finish
- 11.88" x 1.29" vented iron HP smooth face 1-piece integrated hub and rotor
- BP-10 metallic - composite compound *SmartPads*
- Fits all original equipment drum brake spindles
- Fits most 15" style wheels⁽¹⁾
- Works with manual or power brakes
- DOT approved stainless steel braided flexlines are included
- Complete with brackets, hardware, and detailed installation instructions

(1) Go to www.wilwood.com for complete year/make/model application data and specific wheel clearance requirements

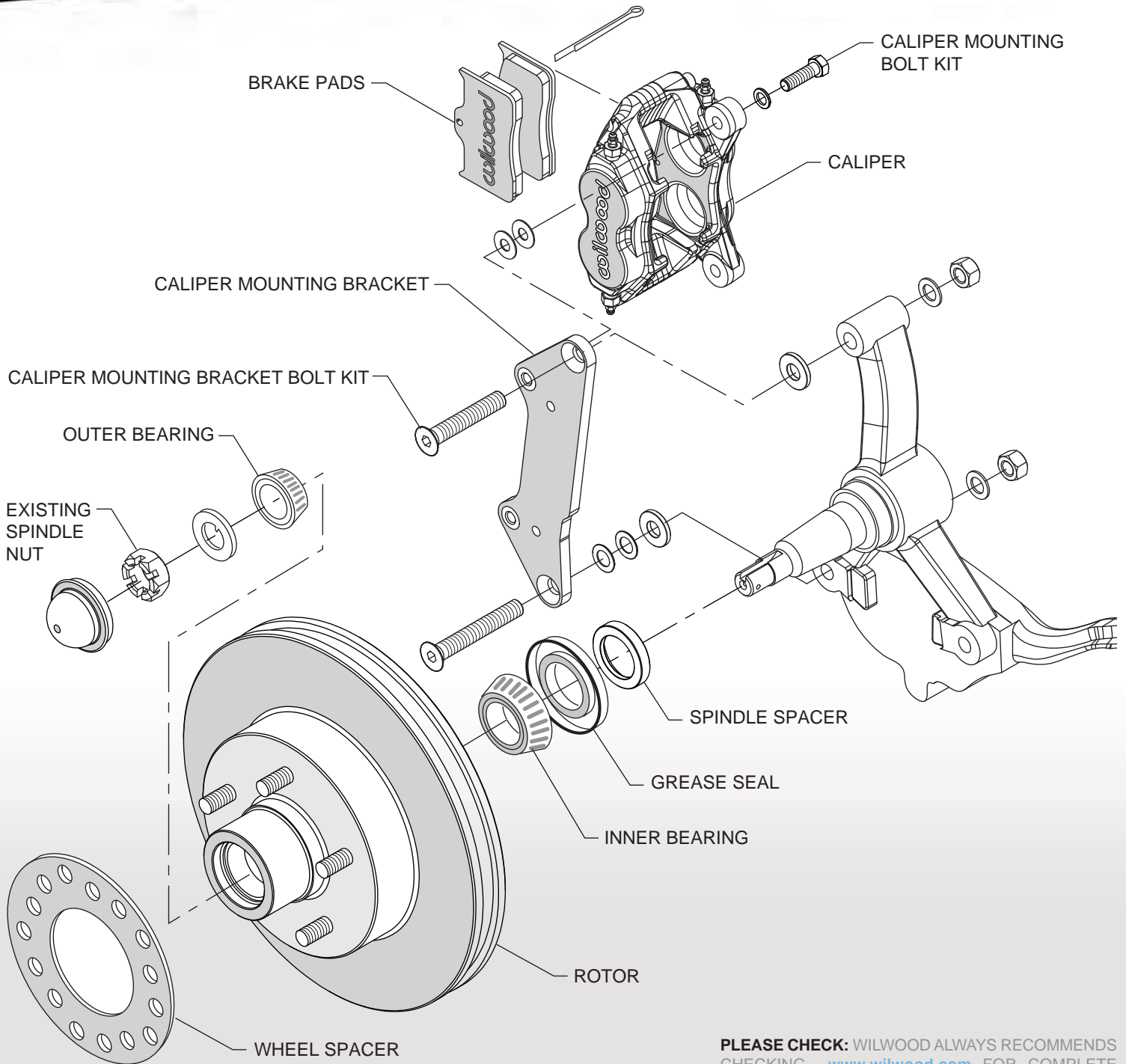

PLEASE CHECK: WILWOOD ALWAYS RECOMMENDS CHECKING www.wilwood.com FOR COMPLETE YEAR/MAKE/MODEL APPLICATION DATA AND SPECIFIC WHEEL CLEARANCE REQUIREMENTS.

ORDERING INFORMATION: Front Brake Kits for 1957-1960 Cadillac

PART NUMBER	DESCRIPTION	CALIPER FINISH
140-15162	Dynalite-M Forged Calipers, 11.88" HP 1-Piece Plain Face Rotors	Black Anodized
140-15162-R	Dynalite-M Forged Calipers, 11.88" HP 1-Piece Plain Face Rotors	Red Powder Coat