

DYNALITE CLASSIC SERIES FRONT DISC BRAKE CONVERSION KIT FOR 1949-1953 FORD

Models Covered:

- Ford, All Models, 1949-1953

Kit Features:

- Front disc brake conversion provides improved stopping power for added safety and driving comfort while maintaining an unmodified outward appearance with Original Equipment (OE) or classic styled wheels.
- Fully bolt-on installation requires no modifications to spindles or suspension. Original components can be reinstalled when factory authenticity may be preferred.
- Fully compatible with OE master cylinder output when a modern tandem outlet master cylinder will not be used

Component Features:

Dynalite Forged Billet Four Piston Calipers

- Dynalite calipers provide big brake stopping power, rugged durability, and a long, corrosion free service life from the FEA computer designed forged billet aluminum body.
- Stainless steel pistons provide additional corrosion resistance while reducing the direct transfer of heat from the pads to the caliper body, fluid, and seals.
- The internal piston seal-in-bore design adds proven durability with keeping the fluid in and dirt out without the need for external boot seals.
- Black anodized finish provides additional resistance to oxidation inside and out to maintain performance and preserve their high-tech style and appearance.

ULHP Integrated Hub / Rotor

- Replacement rotors provide the highest degree of cooling efficiency with increased surface area and improved air circulation between the rotor faces.
- ULHP rotors provide high performance and rugged durability for a wide range of competition, performance, and sport driving applications. Rotors are cast from premium grade, long grain carbon iron.
- Hubs include bearing and seals.

BP-10 Compound “Smart Pads”

- BP-10 metallic composite compound “Smart Pads” provide high friction, high temperature fade resistance, and immediate positive response without the noise, dust, and rotor abrasion that is normally associated with OE type semi-metallic style pads.

Hardware and Plumbing

- Caliper brackets, alignment shims, all premium grade fasteners, and a detailed installation guide are included with each kit.
- Jacketed stainless steel braided, DOT approved flexline kits are included with the kit.



Front Dynalite Classic Series Kit

Download high resolution photo,
[click here](#)

WARNING
 INSTALLATION OF THIS KIT SHOULD **ONLY** BE PERFORMED BY PERSONS EXPERIENCED IN THE INSTALLATION AND PROPER OPERATION OF DISC BRAKE SYSTEMS.

NOTE
 SPECIFIC PARTS MAY VARY FROM DIAGRAM

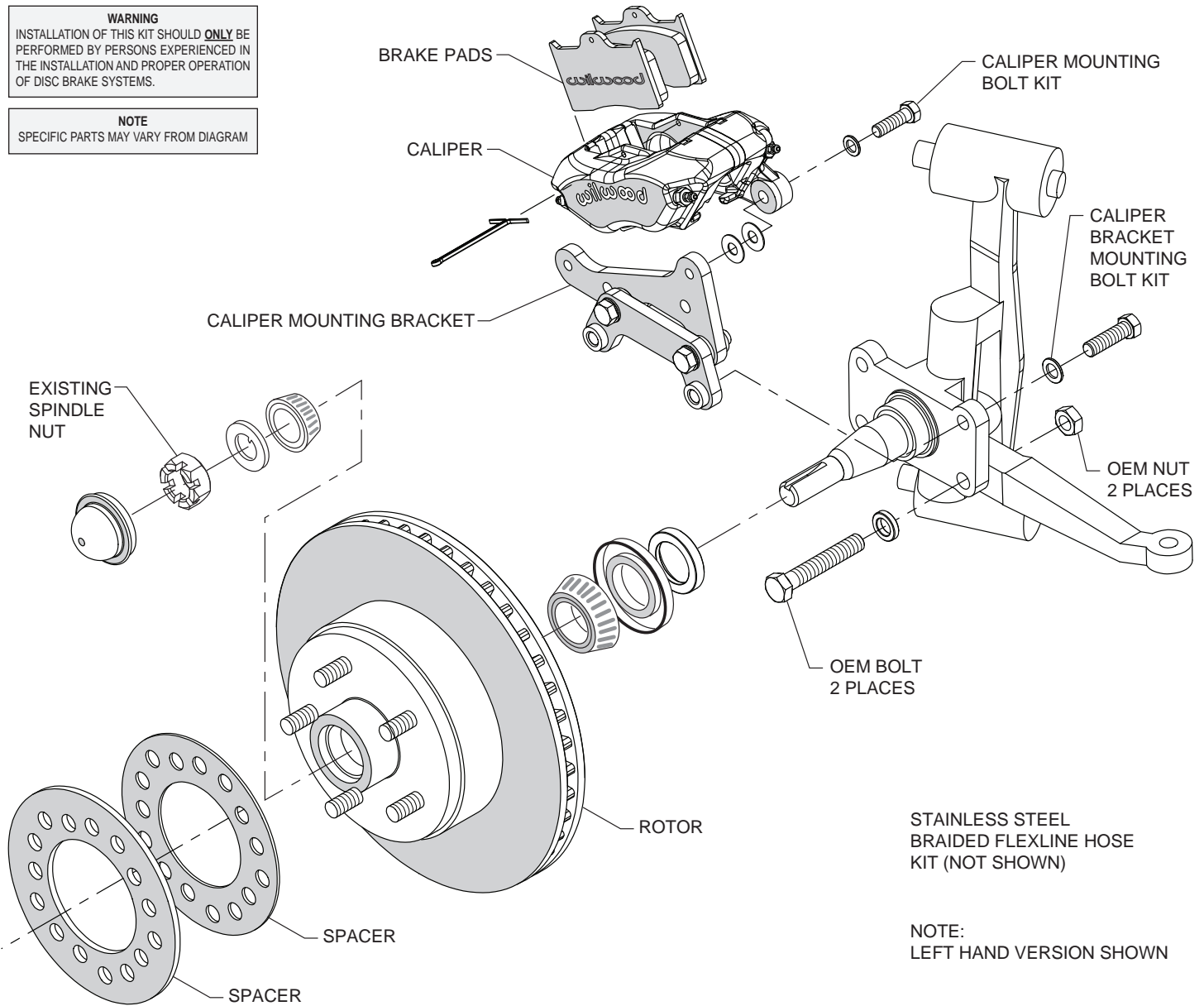

Typical Installation Diagram

ORDERING INFORMATION:

PART NUMBER

140-12913

DESCRIPTION

Front Kit, Ford, Dynalite Caliper, 11.28" HP Plain Face Rotor



Need additional information - fast? Utilizing your Smartphone, scan the image at the left to jump to our web site. This code takes you to our home page and social media sites where information is just a click away, [or click here.](#)