

ASSEMBLY INSTRUCTIONS

FOR

GM G-BODY WITH 2.62" AXLE OFFSET*

*For additional vehicle compatibility, visit www.wilwood.com

**FORGED NARROW
SUPERLITE 4R
REAR BRAKE KIT
WITH 12.88" GT
VENTED ROTORS**

BASE PART NUMBER

140-17658

OR

**FORGED NARROW
SUPERLITE 4R
REAR BRAKE KIT
WITH 14.00" GT
VENTED ROTORS**

BASE PART NUMBER

140-17659

**DISC BRAKES SHOULD ONLY BE INSTALLED BY SOMEONE
EXPERIENCED AND COMPETENT IN THE INSTALLATION AND
MAINTENANCE OF DISC BRAKES
READ ALL WARNINGS**

WARNING

IT IS THE RESPONSIBILITY OF THE PERSON INSTALLING ANY BRAKE COMPONENT OR KIT TO DETERMINE THE SUITABILITY OF THE COMPONENT OR KIT FOR THAT PARTICULAR APPLICATION. IF YOU ARE NOT SURE HOW TO SAFELY USE THIS BRAKE COMPONENT OR KIT, YOU SHOULD NOT INSTALL OR USE IT. DO NOT ASSUME ANYTHING. IMPROPERLY INSTALLED OR MAINTAINED BRAKES ARE DANGEROUS. IF YOU ARE NOT SURE, GET HELP OR RETURN THE PRODUCT. YOU MAY OBTAIN ADDITIONAL INFORMATION AND TECHNICAL SUPPORT BY CALLING WILWOOD AT (805) 388-1188, OR VISIT OUR WEB SITE AT WWW.WILWOOD.COM. USE OF WILWOOD TECHNICAL SUPPORT DOES NOT GUARANTEE PROPER INSTALLATION. **YOU**, OR THE PERSON WHO DOES THE INSTALLATION MUST KNOW HOW TO PROPERLY USE THIS PRODUCT. IT IS NOT POSSIBLE OVER THE PHONE TO UNDERSTAND OR FORESEE ALL THE ISSUES THAT MIGHT ARISE IN YOUR INSTALLATION.

RACING EQUIPMENT AND BRAKES MUST BE MAINTAINED AND SHOULD BE CHECKED REGULARLY FOR FATIGUE, DAMAGE, AND WEAR.



Need Additional Information? Use Your
SmartPhone and Jump to Our Technical
Tips Section on Our Web Site.



WARNING

**DO NOT OPERATE ANY VEHICLE ON UNTESTED BRAKES!
SEE MINIMUM TEST PROCEDURE WITHIN**

ALWAYS UTILIZE SAFETY RESTRAINT SYSTEMS AND ALL OTHER AVAILABLE SAFETY EQUIPMENT WHILE OPERATING THE VEHICLE

IMPORTANT • READ THE DISCLAIMER OF WARRANTY INCLUDED IN THE KIT

NOTE: Some cleaners may stain or remove the finish on brake system components. Test the cleaner on a hidden portion of the component before general use.

Important Notice - Read This First

Before any tear-down or disassembly begins, review the following information:

- A substantial amount of modifications are required to the axle housing flange. These include removing material that will interfere with the assembly of the Wilwood disc brake kit as well as drilling two holes. It is recommended that these modifications be performed by a qualified machine shop. Keep in mind that this may require a substantial amount of time. Therefore, the vehicle may be inoperable for longer than anticipated.
- Review the Wheel Clearance Diagram (Figures 2 & 3, page 4) to verify that there is adequate clearance with the wheels you will be using with the installation.
- Verify the rear axle housing flange pattern, axle offset, and other critical measurements as outlined on page 4.
- This brake kit is not supplied with hydraulic lines or fittings and may require the purchase of additional lines or fittings to complete the installation. Wilwood offers an extensive listing of brake lines and fittings on our web site: www.wilwood.com.
- This brake kit is not supplied with parking brake cables hardware or adapters. Please see the note in the assembly instructions for vendor recommendations to purchase these parts.
- Due to OEM production differences and other variations from vehicle to vehicle, the fastener hardware and other components in this kit may not be suitable for a specific application or vehicle.
- It is the responsibility of the purchaser and installer of this kit to verify suitability / fitment of all components and ensure all fasteners and hardware achieve complete and proper engagement. Improper or inadequate engagement can lead to component failure.

Exploded Assembly Diagram

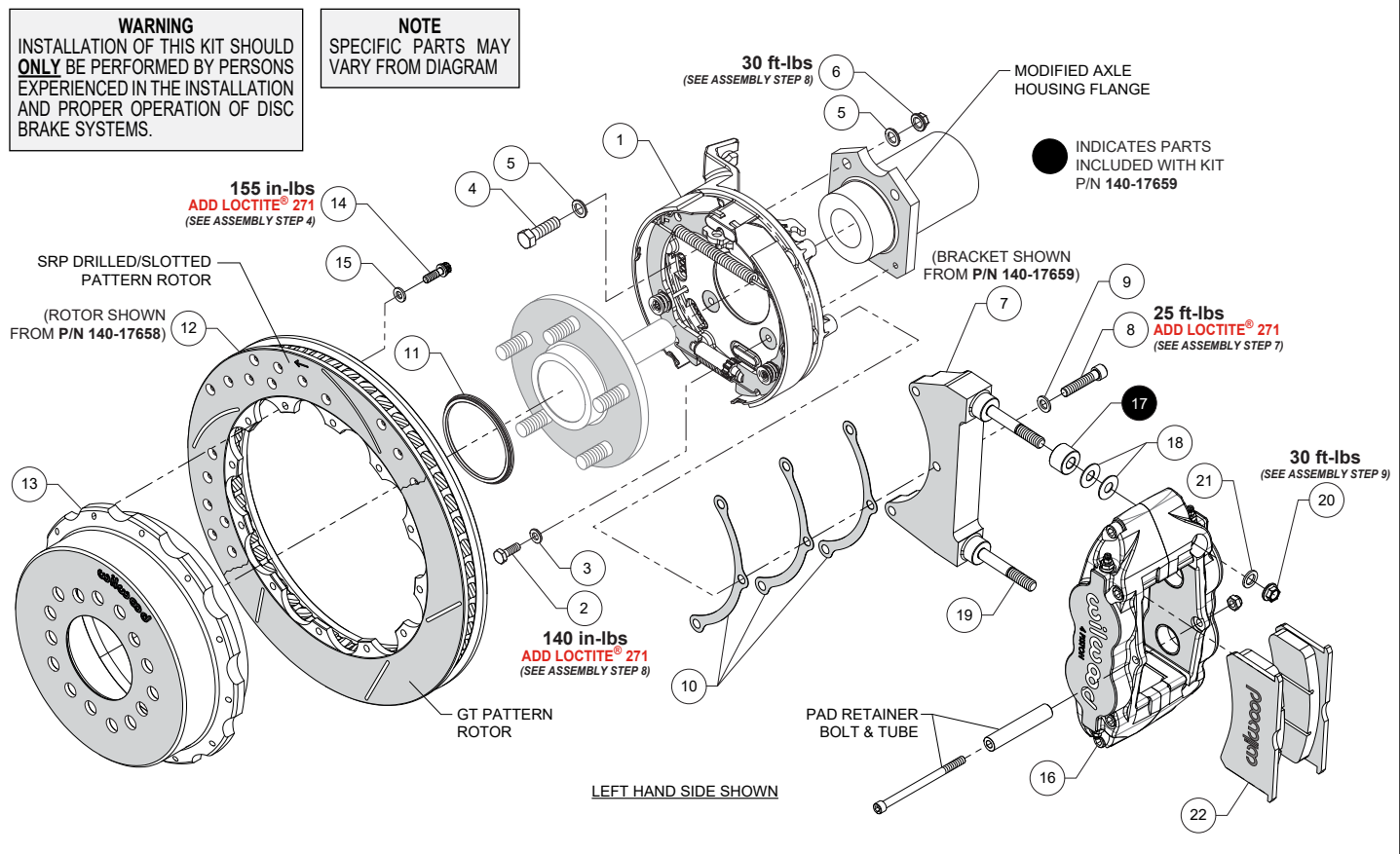

Figure 1. Typical Installation Configuration

Photographic Tip

Important and highly recommended: Take photos of brake system before disassembly and during the disassembly process. In the event, trouble-shooting photos can be life savers. Many vehicles have undocumented variations, photos will make it much simpler for Wilwood to assist you if you have a problem.

Parts List

ITEM NO.	PART NO.	DESCRIPTION	QTY
1	249-17122/23	Backing Plate Assembly, .642" Offset (one each, right and left)	2
2	230-17154	Bolt, M6-1.00 x 20mm Long, Hex Head	4
3	240-11240	Washer, .265" I.D. x .500" O.D. x .063" Thick	4
4	230-10025	Bolt, 3/8-24 x 1.25" Long, Hex Head	4
5	240-10190	Washer, .391" I.D. x .625" O.D. x .063" Thick	8
6	230-16550	Nut, 3/8-24, Self Locking	4
7	249-16227/28	Bracket, Caliper Mounting (one each, right and left)	2
8	230-13564	Bolt, 5/16-24 x 1.50" Long, Socket Head	6
9	240-10191	Washer, .328" I.D. x .562" O.D. x .063" Thick	6
10	300-16237	Shim, Bracket, .015" Thick	10
11	300-11532	Adapter, Rotor Registration, 2.78" Diameter	2
12	160-12961/62-GTB	Rotor, GT, 1.10" Thick x 12.88" Diameter - included with kit p/n 140-17658	2
12A	160-13543/44-BK	Rotor, SRP Drilled and Slotted - option for kit p/n 140-17658	2
12	160-8402/03-GTB	Rotor, GT, 1.10" Thick x 14.00" Diameter - included with kit p/n 140-17659	2
12B	160-8400/01-BK	Rotor, SRP Drilled and Slotted - option for kit p/n 140-17659	2
13	170-13540	Hat, 12 x 8.75" Bolt Circle, 5 x 4.50"/4.75"/5.00" Stud Patterns	2
14	230-8037	Bolt, 1/4-20 x .75" Long, 12 Point	24
15	240-11240	Washer, .265" I.D. x .500" O.D. x .063" Thick	24
16	120-11782-BK	Caliper, Forged Narrow SuperLite, Black	2
16A	120-11782-RD	Caliper, Forged Narrow SuperLite, Red	2
17	300-7392	Spacer, .573" Long - included with kit p/n 140-17659	4
18	240-1159	Shim, .035" Thick	16
19	230-9078	Stud, 3/8-16, 3/8-24 x 2.50" Long - included with kit p/n 140-17658	4
19	230-9079	Stud, 3/8-16, 3/8-24 x 3.15" Long - included with kit p/n 140-17659	4
20	230-16550	Nut, 3/8-24, Self Locking	4
21	240-10190	Washer, .391" I.D. x .625" O.D. x .063" Thick	4
22	150-8850K	Pad, BP-10 Compound, Axle Set	1

NOTES:

Part Number 230-8008 Rotor Bolt Kit, includes p/ns 230-8037 and 240-11240

Part Number 230-16332 Bracket Mounting Bolt Kit, includes p/ns 230-13564, and 240-10191

Part Number 230-17191 Backing Plate Bolt Kit, includes p/ns 230-10025, 230-16550, 230-17154, 240-10190, and 240-11240

Part Number 249-16335/36 Caliper Mounting Bolt Kit, includes p/ns 230-9078, 230-16550, 240-1159, 240-10190, 249-16227/28, and 300-16237

Item 12A & 12B are optional items and included in the "-D" drilled rotor kits. Add "-D" to end of part number when ordering.

Item 16A is an optional item and included in the "-R" red caliper kits. Add "-R" to end of part number when ordering.

General Information

•Installation of this kit should **ONLY** be performed by persons experienced in the installation and proper operation of disc brake systems. Before assembling this Wilwood disc brake kit, double check the following to ensure a trouble free installation.

•Inspect the contents of this kit against the parts list to ensure that all components and hardware are included.

•Make sure this is the correct kit to fit the axle housing flange, not necessarily the rear end make. Many times aftermarket manufacturers put a different make of axle housing flange on the stock rear end housing (Figure 6). Example; Big Ford rear ends with Olds-Pontiac flanges, therefore, an Olds-Pontiac rear disc brake kit would be the correct kit to order. Also, shock clearance may be a problem. They may have to be modified and/or relocated to clear the Wilwood kit after final assembly.

•Verify your wheel clearance using Figures 2 and 3.

•Verify The Following Measurements Before Assembly

•Axle housing flange mounting pattern to pattern in bracket.

•Stud pattern on axle flange to stud pattern in rotor/hat.

•Axle center register diameter is 2.78", Figure 4. This kit uses Wilwood's removable center register adapters. Rotors can either be centered on the axle register, i.e. *register-centric* or centered on the wheel studs, i.e. *stud-centric*. Due to variations in wheel stud final diameters, *register-centric* centering can be a more accurate method of centering the rotor to the axle. Wilwood offers various diameter adapters for purchase in addition to the ones supplied in this kit, see Table 1.

•Dimension from wheel side of axle flange to wheel side of axle housing flange (see Figure 6, lower right hand corner). This dimension is critical to ensure proper alignment of the rotor to the caliper, and should match offset given in the kit description.

•The Wilwood hat utilized in this kit is drilled for 1/2" diameter wheel studs. **NOTE: Some OEM axles have 7/16" (0.44") wheel axle studs.** It is recommended that you upgrade to 1/2" studs. Dependent on the type of axle, this may be a simple stud change, or may require the services of a machine shop to perform.

•Maximum axle flange diameter must be no larger than 6.61" w/.050" x 45° chamfer, Figure 4.

General Information (Continued)

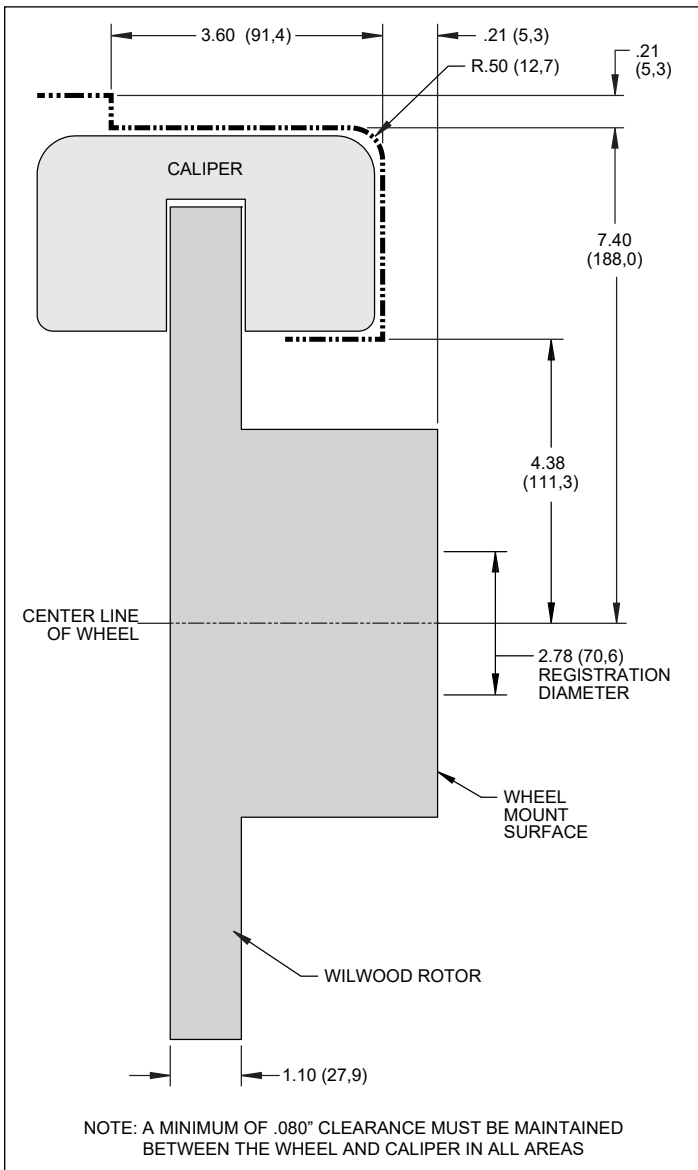

**Figure 2. Wheel Clearance Diagram
p/n 140-17658 - 12.88" Rotors**

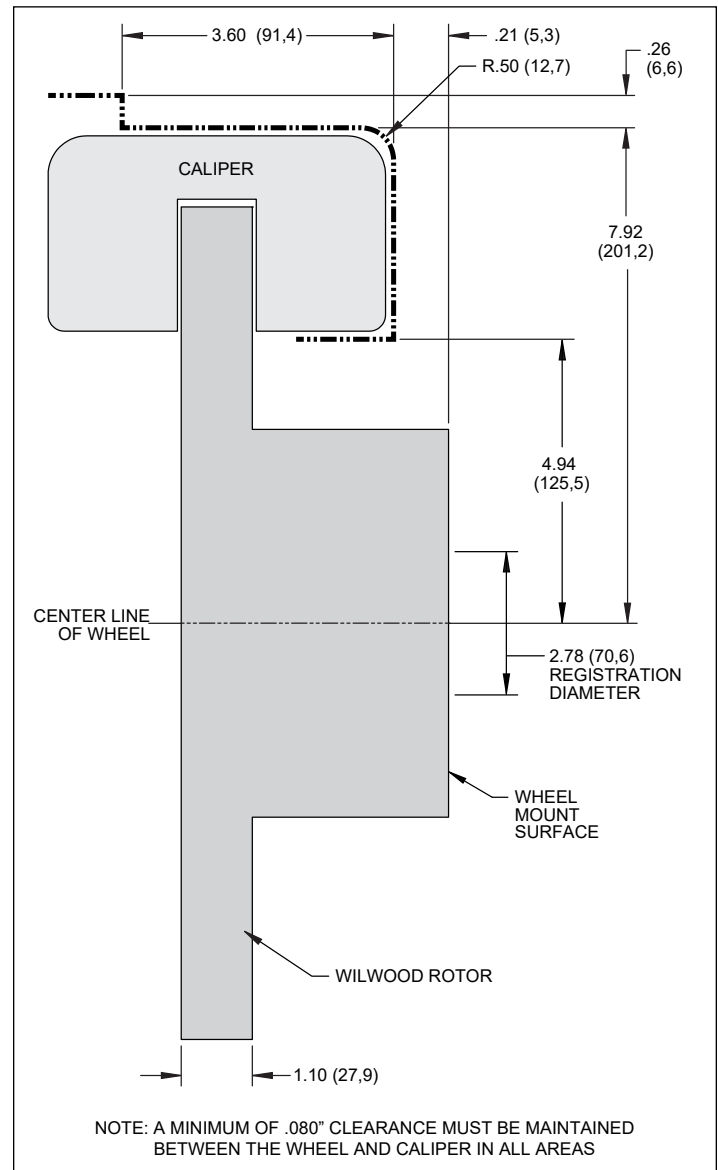

**Figure 3. Wheel Clearance Diagram
p/n 140-17659 - 14.00" Rotors**

Disassembly Instructions

- Disassemble the original equipment rear brakes:

Raise the rear wheels off the ground and support the rear suspension according to the vehicle manufacturer's instructions.

Remove the rear wheels and disassemble the drum brake assembly down to the bare axle.

Remove the axle shaft and backing plate.

- Remove any nicks or burrs on the axle housing flange, as well as the axle flange, that may interfere with the installation of the new brake components.

- Clean and de-grease the axle and axle housing flange.

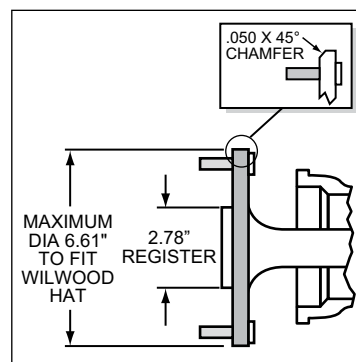

**Figure 4. Axle Flange
Maximum Dimension**

This kit includes a 3.06" center I.D. hat or rotor assembly and a 2.78" hub register adapter ring to accommodate the installation of this kit on axles of either dimension. For axles with different center register diameters, please consult the table below for optional adapter ring sizes.

PART NO.	REGISTER I.D.	NOTE
NO ADAPTER USED	3.06"	ROTOR CENTER HOLE I.D.
300-13328	2.88"	OPTIONAL
300-11732	2.86"	OPTIONAL
300-11962	2.84"	OPTIONAL
300-11338	2.82"	OPTIONAL
300-11337	2.80"	OPTIONAL
300-13506	2.79"	OPTIONAL
300-11532	2.78"	SUPPLIED WITH KIT
300-16434	2.75"	OPTIONAL
300-11803	2.52"	OPTIONAL
300-11901	2.50"	OPTIONAL
300-12761	2.44"	OPTIONAL
300-11653	2.18"	OPTIONAL
300-11339	2.00"	OPTIONAL (Machine to fit I.D.)

Table 1. Center Register Adapters

Axle Housing Flange Modification Instructions

NOTE: Numbers in parenthesis refer to the parts list and Figure 1 on the preceding pages.

• The upper raised portion of axle housing flange must be removed and two holes drilled to facilitate the installation of the Wilwood brake kit.

• First, remove upper raised area of flange as indicated in Photo A. **CAUTION:** Do not remove too much of the lower, non-raised area. Leave enough material to allow drilling of two 3/8" holes as indicated.

• Utilizing the lower threaded holes previously used for the OE backing plate, attach Wilwood backing plate (1) to axle housing flange using Wilwood bolts (2). Use the upper mounting holes of backing plate as a template to drill new 3/8" holes into axle housing flange.

• Ensure the parking brake lever movement is unobstructed by the flange. Some additional grinding of flange may be necessary, Photo B.

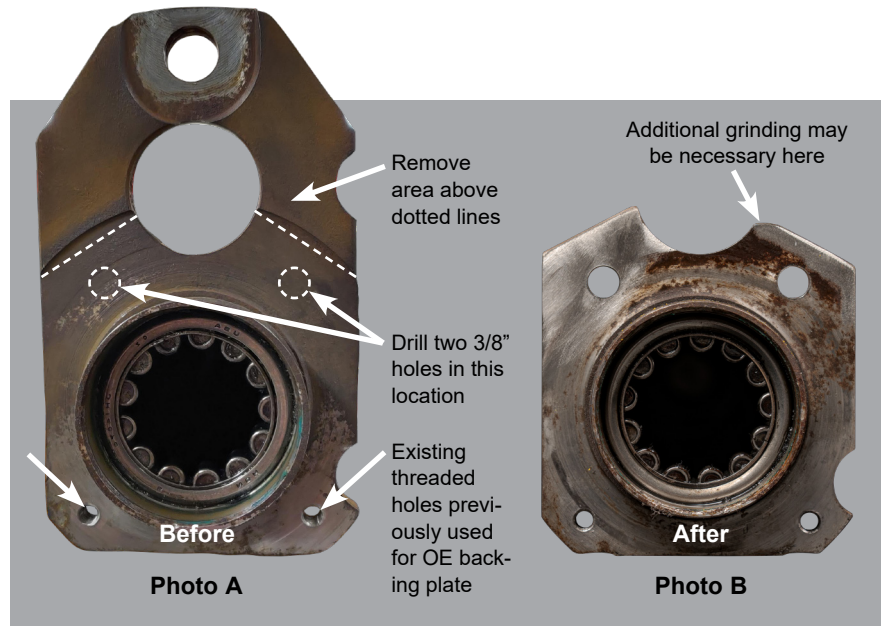

Assembly Instructions

IMPORTANT:

- To ensure maximum performance from your parking brake system, the cables must be routed as straight as possible. Bends in the cable can significantly reduce efficiency and thus reduce pull force at the brake. Tight bends must be avoided with a minimum recommended bend radius of 6" to 8".
- Cables should be properly restrained to prevent "straightening" of bends when tension is applied. Restrain movement of cable by affixing the cable sheath to body or chassis by fitting cable clamps at various points over the length of cable or by using original equipment cable attachments points. The clamping method chosen will require that cable sheath be held tightly without movement, crushing or causing interference to the internal cable.
- Cables must be initially pre-stretched by multiple applications of the brake handle, then re-adjusted to correct tension.

NOTE: Numbers in parenthesis refer to the parts list and Figure 1 on the preceding pages.

CAUTION: The OEM shock mount bracket on the axle housing may interfere with the installation of this kit. Ensure the steps are followed in sequence with special attention to notes in Steps 2 & 7.

STEP 1 Attach backing plate assembly to lower threaded holes of axle housing flange using bolts (2), and washers (3), as shown in Photo 1 (arrows). Use bolts (4), washers (5), and lock nuts (6) on remaining upper bolt holes to finish attaching backing plate to axle housing, Figure 1. Temporarily tighten all the mounting bolts and nuts. **NOTE:** The backing plate must fit squarely against the axle housing flange face. Inspect for interference from casting irregularities, machining ridges, burrs, etc. Ensure that the parking brake lever movement is unobstructed by the axle flange (arrow, Photo 3). Later, after the caliper alignment has been checked, the mount bolts will be secured using red Loctite® 271.

STEP 2 The radial mount caliper bracket (7) should initially be installed with clean, dry threads on the mounting bolts. Orient the

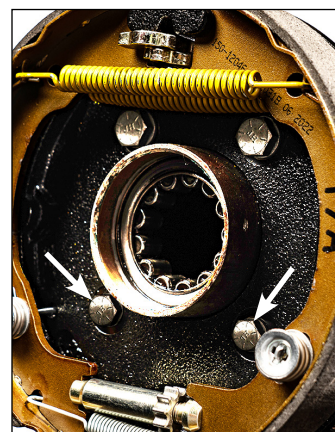

Photo 1



Photo 2

bracket, as shown in Figure 1 and Photo 3, and install using bolts (8) and washers (9). **NOTE:** Initially install bracket using only the top and middle bolt holes. Later, after the caliper alignment has been checked, the lower, third bolt hole will be utilized. Initially place three .015" thick

Assembly Instructions (Continued)

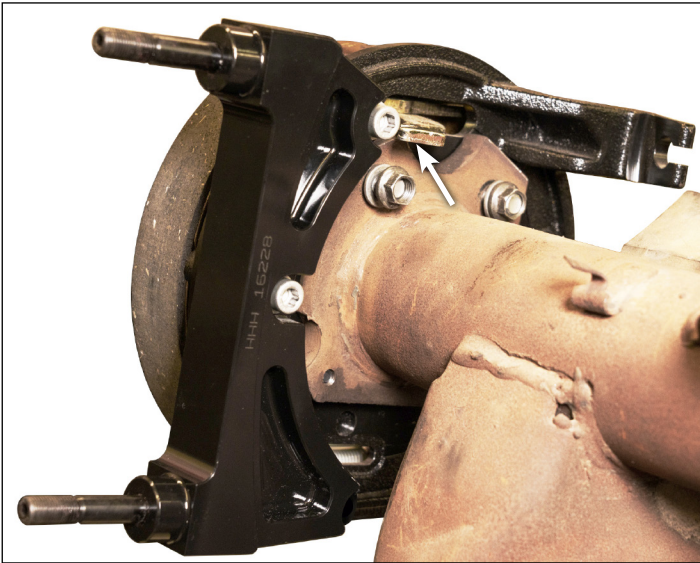

Photo 3



Photo 4

shims (10) on the two upper mounting bolts (8), between the bracket and the backing plate of the parking brake assembly (1), Figure 1, Photo 2. Temporarily tighten the mounting bolts. **NOTE:** *The bracket must fit squarely against the mount bosses on the backing plate.* Inspect for interference from casting irregularities, machining ridges, burrs, etc. Later, after the caliper alignment has been checked, the mount bolts will be secured using red *Loctite*[®] 271.

STEP 3 Slide the axle into the axle housing and secure following OEM instructions. **NOTE:** *Do not install differential cover until brake kit installation is complete.* Install the rotor registration adapter (11) onto the axle flange with the smaller O.D. facing toward the rotor/hat (12/13), Photo 4.

STEP 4 Orient the rotor (12) and the hat (13) as shown in Figure 1 and Photo 5. Attach rotor to hat using bolts (14) and washers (15). Apply red *Loctite*[®] 271 to the bolt threads and torque to



Photo 5

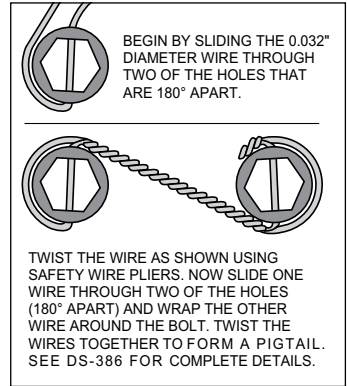

Figure 5
Safety Wire Diagram



Photo 6

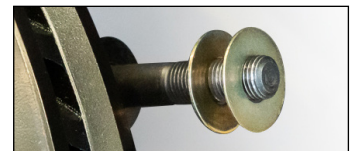

Photo 7
p/n 140-17658



Photo 8
p/n 140-17659

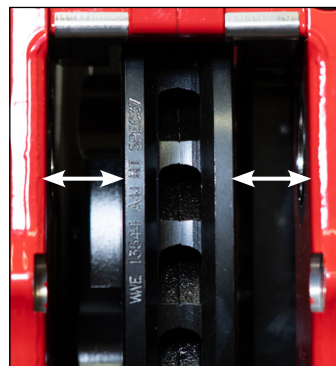

Photo 9

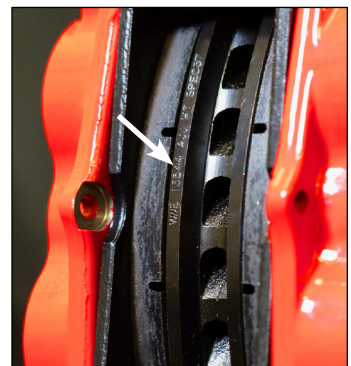

Photo 10

value shown in Figure 1 using a criss-cross pattern. For an added measure of security, the bolts may be safety wired using standard 0.032 inch diameter stainless steel safety wire as shown in Figure 5. Refer to Wilwood's data sheet DS-386 (available at www.wilwood.com/Pdf/DataSheets/ds386.pdf) for complete safety wire installation instructions.

STEP 5 Align the correct hole pattern in the rotor/hat with the stud pattern on the axle flange and slide into place, Figure 1 and Photo 6. **NOTE:** *The rotor/hat must fit flush against the axle flange or excessive rotor run out may result.* Install three lug nuts (finger tight) to keep the rotor/hat assembly in place while continuing with the installation. **NOTE:** *Some OEM and after market axles*

Assembly Instructions (Continued)

come with stud sizes larger than 1/2" diameter. Verify stud size and have a qualified machine shop drill the bolt circle of the hat/rotor to the correct stud size, if necessary.

STEP 6 NOTE: Follow one of the procedures below based on which brake kit you have purchased.

•For kit p/n 140-17658: Initially place two .035" thick shims (18) on each stud (19) between the caliper and the radial mount caliper bracket, as shown in Figure 1 and Photo 7.

•For kit p/n 140-17659: Initially place spacer (17) and two .035" thick shims (18) on each stud (19) between the caliper and the radial mount caliper bracket, as shown in Figure 1 and Photo 8.

STEP 7 Mount the caliper (16) onto the radial mount caliper bracket (7) using lock nuts (20) and washers (21), Figure 1. Temporarily tighten the lock nuts and view the rotor through the top opening of the caliper. The rotor should be centered in the caliper, Photo 9. If not, adjust by adding or subtracting .015" shims (10) as necessary between the radial mount caliper bracket (7) and the backing plate of the parking brake

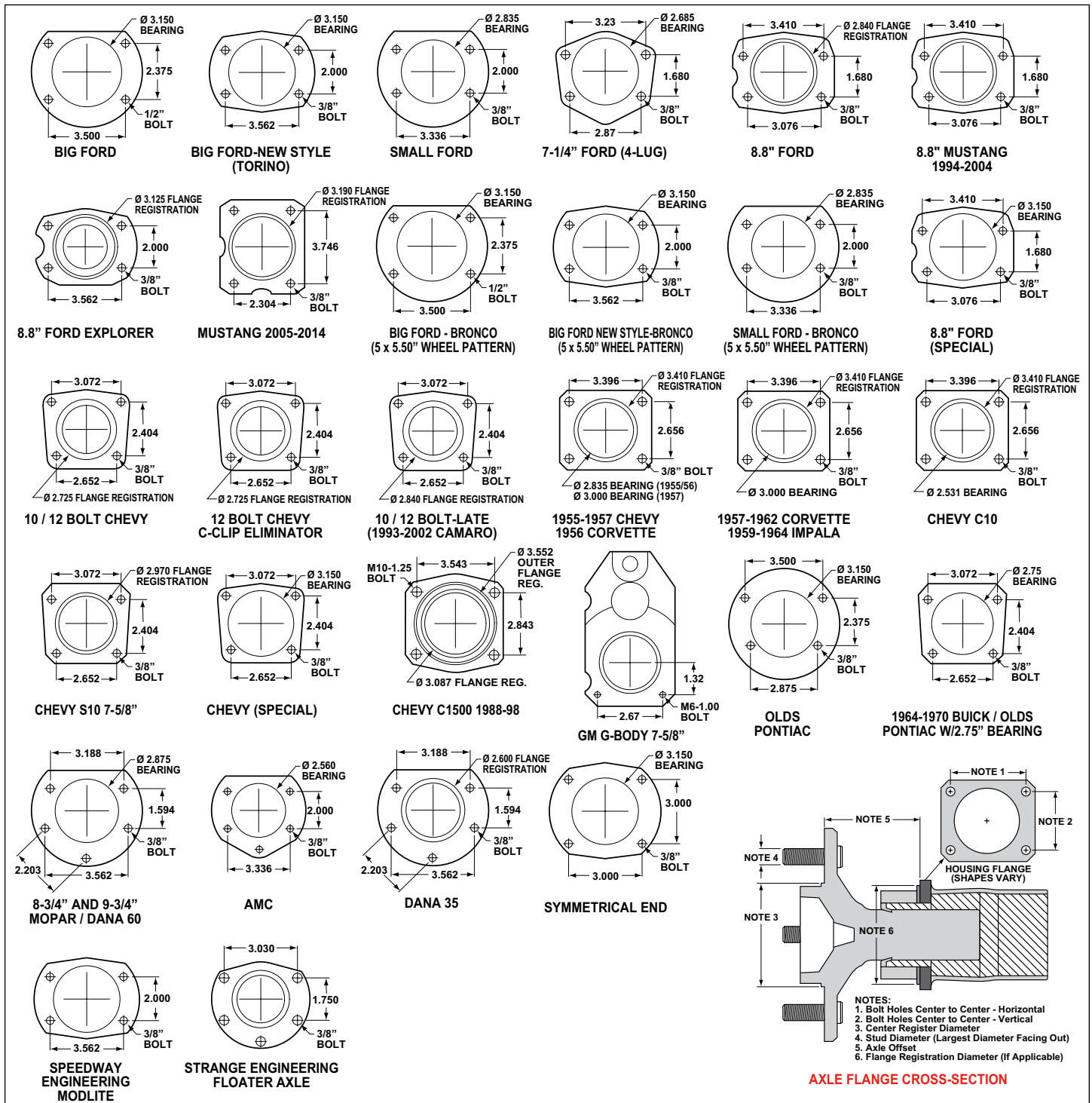

Figure 6. Rear Housing Flange Chart and Axle Flange / Offset Cross-Section

Assembly Instructions (Continued)

assembly (1). Once the caliper alignment is correct, remove the caliper, rotor assembly, axle, and backing plate assembly. **NOTE:** *The third, lower bracket bolt will now be utilized.* Remove the two caliper bracket bolts (8), apply red *Loctite*[®] 271 to the threads and reinstall bolts. Install the third lower bolt (8), also applying red *Loctite*[®] 271 to the threads, and torque all three bolts to value shown in Figure 1.

STEP 8 Reinstall the backing plate/caliper bracket assembly onto the axle housing flange by following Step 1. Apply red *Loctite*[®] 271 to the bolt threads (2) and torque to value shown in Figure 1. Torque locknuts (6) to value shown in Figure 1. Reinstall the axle into the axle housing and repeat Steps 5 thru 7 for reinstalling the rotor/hat assembly and caliper.

STEP 9 Remove the caliper pad retainer bolt, nut, and tube from the caliper, see Figure 1. Insert the brake pads (22) into the caliper, with the friction material facing the rotor, as shown in Figure 1. Check that the top of the brake pad is flush with the outside diameter of the rotor, Photo 10. If not, adjust by adding or subtracting shims (18) on each stud between the caliper and the bracket/spacer. After the caliper pad height is set, torque the caliper lock nuts (20) to value shown in Figure 1. Secure the brake pads in place with the pad retainer tube, bolt, and locknut. The locknut should be snug without play in the bolt or tube. Be cautious not to over tighten.

STEP 10 Temporarily install the wheel and torque lug nuts to manufacturer's specification. Ensure that the wheel rotates freely without any interference. Remove wheel for next step.

•**NOTE:** *Clevis and cable kits which attach to the parking brake assembly are not included in the Wilwood parking brake kit. Wilwood offers a generic style parking brake cable kit, P/N 330-9371 for this application which can be ordered separately from your local Wilwood dealer or by calling Wilwood customer service at (805) 388-1188.*

STEP 11 Install three lug nuts to hold the rotor/hat (12/13) securely in place, remove the rubber grommet in the backing plate kit assembly (1) and adjust the parking brake shoes outward (using a drum shoe adjustment tool available at your local auto parts store) while spinning the rotor/hat (12/13) until a slight drag is felt against the hat/drum. Replace the rubber grommet when finished.

STEP 12 Attach brake line to caliper. **NOTE:** *OEM rubber brake hoses generally cannot be adapted to Wilwood calipers.* The caliper inlet fitting is a 1/8-27 NPT. The preferred method is to use

steel adapter fittings at the caliper, either straight, 45 or 90 degree (use PTFE tape on pipe threads of adapter fitting for proper sealing to caliper). **Ensure hoses are routed to prevent contact with moving suspension, brake or wheel components.** Wilwood offers universal brake flex line hose kits (sold separately). For domestic (3/8-24 IF) chassis fittings, order:

P/N 220-7056 for the 14 inch length domestic, 3/8-24 IF
P/N 220-7699 for the 16 inch length domestic, 3/8-24 IF
P/N 220-8307 for the 18 inch length domestic, 3/8-24 IF
Hose kits include hoses, fitting, etc., all in one package for this application.

•**NOTE:** *Wilwood hose kits are designed for use in many different vehicle applications and it is the installer's responsibility to properly route and provide adequate clearance and retention for brake hose components.*

•**NOTE:** *Specified brake hose kits may not work with all Years, Makes and Models of vehicle that this brake kit is applicable to, due to possible OEM manufacturing changes during a production vehicle's life.*

•**CAUTION:** *In absence of specific instructions for brake line routing, the installer must use his best professional judgment on correct routing and retention of lines to ensure safe operation. It is the installer's responsibility to ensure that all fittings and hoses are the correct size and length, properly seal, and that they will not be subject to crimping, strain and abrasion from vibration or interference with suspension components, brake rotor or wheel.*

STEP 13 Bleed the brake system, referring to the 'Additional Information and Recommendations' on page 9 for proper bleeding instructions. Check system for leaks after bleeding.

STEP 14 Install the wheel and torque the lug nuts to manufacturer's specifications.

•**CAUTION:** *Test vehicle brake system per the 'Minimum Test Procedure' stated within this document before driving. After road testing, inspect for leaks and interference. Initially after install and testing, perform frequent checks of the vehicle brake system and lines before driving, to confirm that there is no undue wear or interference not apparent from the initial test. Afterwards, perform periodic inspections for function, leaks and wear in an interval relative to the usage of vehicle.*

STEP 15 Bed-in the brake pads per the procedure on page 10.

Additional Information and Recommendations

•Please read the following concerning balancing the brake bias on 4 wheel disc vehicles.

•OE Style or Single Mount Race Pedal with Tandem Outlet Master Cylinder:

Front to rear caliper piston sizes, rotor diameters, and pad compounds must be initially configured to provide the correct range of vehicle bias when using a single bore / tandem outlet master cylinder. If excessive rear brake bias is experienced, an inline adjustable proportioning valve can be used to decrease the rear line pressure to help bring the vehicle into balance. If excessive front brake bias is experienced, first consideration should be given to increasing the rear brake bias to bring the vehicle into overall balance.

•Race Pedal with Dual Master Cylinders and Balance Bar:

Master cylinders must be sized to match the calipers and allow the pedal balance bar to operate near the center of its travel. If it is not

Additional Information and Recommendations (Continued)

possible to fine tune the bias within the adjustable range of the balance bar, then consideration must be given to changing a master cylinder bore size or some other aspect of the brake system to bring the car into balance. Larger bore master cylinders will generate less pressure while decreasing pedal travel. Smaller bores master cylinders will generate higher line pressures with an increase in pedal travel.

- Fill and bleed the new system with Wilwood Hi-Temp° 570 grade fluid or higher. For severe braking or sustained high heat operation, use Wilwood EXP 600 Plus Racing Brake Fluid. Used fluid must be completely flushed from the system to prevent contamination. **NOTE:** *Silicone DOT 5 brake fluid is **NOT** recommended for racing or performance driving.*

- To properly bleed the brake system, begin with the caliper farthest from the master cylinder. Bleed the outboard bleed screw first, then the inboard. Repeat the procedure until all calipers in the system are bled, ending with the caliper closest to the master cylinder. **NOTE:** *When using a new master cylinder, it is important to bench bleed the master cylinder first.*

- If the master cylinder is mounted lower than the disc brake calipers, some fluid flowback to the master cylinder reservoir may occur, creating a vacuum effect that retracts the caliper pistons into the housing. This will cause the pedal to go to the floor on the first stroke until it has “pumped up” and moved all the pistons out against the pad again. A Wilwood in-line two pound residual pressure valve, installed near the master cylinder will stop the fluid flowback and keep the pedal firm and responsive.

- Test the brake pedal. It should be firm, not spongy and stop at least 1 inch from the floor under heavy load.

If the brake pedal is spongy, bleed the system again.

If the brake pedal is initially firm, but then sinks to the floor, check the system for fluid leaks. Correct the leaks (if applicable) and then bleed the system again.

If the brake pedal goes to the floor and continued bleeding of the system does not correct the problem, a master cylinder with increased capacity (larger bore diameter) will be required. Wilwood offers various lightweight master cylinders with large fluid displacement capacities.

- **NOTE:** *With the installation of after market disc brakes, the wheel track may change depending on the application. Check your wheel offset before final assembly.*

- If after following the instructions, you still have difficulty in assembling or bleeding your Wilwood disc brakes, consult your local chassis builder, or retailer where the kit was purchased for further assistance.

Brake Testing

WARNING • DO NOT DRIVE ON UNTESTED BRAKES BRAKES MUST BE TESTED AFTER INSTALLATION OR MAINTENANCE MINIMUM TEST PROCEDURE

- Make sure pedal is firm: Hold firm pressure on pedal for several minutes, it should remain in position without sinking. If pedal sinks toward floor, check system for fluid leaks. **DO NOT** drive vehicle if pedal does not stay firm or can be pushed to the floor with normal pressure.
- At very low speed (2-5 mph) apply brakes hard several times while turning steering from full left to full right, repeat several times. Remove the wheels and check that components are not touching, rubbing, or leaking.
- Carefully examine all brake components, brake lines, and fittings for leaks and interference.
- Make sure there is no interference with wheels or suspension components.
- Drive vehicle at low speed (15-20 mph) making moderate and hard stops. Brakes should feel normal and positive. Again check for leaks and interference.
- Always test vehicle in a safe place where there is no danger to (or from) other people or vehicles.
- Always wear seat belts and make use of all safety equipment.

Pad and Rotor Bedding (Continued)

BEDDING STEPS FOR NEW PADS AND ROTORS – ALL COMPOUNDS

Once the brake system has been tested and determined safe to operate the vehicle, follow these steps for the bedding of all new pad materials and rotors. These procedures should only be performed on a race track, or other safe location where you can safely and legally obtain speeds up to 65 MPH, while also being able to rapidly decelerate.

- Begin with a series of light decelerations to gradually build some heat in the brakes. Use an on-and-off the pedal technique by applying the brakes for 3-5 seconds, and then allow them to fully release for a period roughly twice as long as the deceleration cycle. If you use a 5 count during the deceleration interval, use a 10 count during the release to allow the heat to sink into the pads and rotors.
- After several cycles of light stops to begin warming the brakes, proceed with a series of medium to firm deceleration stops to continue raising the temperature level in the brakes.
- Finish the bedding cycle with a series of 8-10 hard decelerations from 55-65 MPH down to 25 MPH while allowing a proportionate release and heat-sinking interval between each stop. The pads should now be providing positive and consistent response.
- If any amount of brake fade is observed during the bed-in cycle, immediately begin the cool down cycle.
- Drive at a moderate cruising speed, with the least amount of brake contact possible, until most of the heat has dissipated from the brakes. Avoid sitting stopped with the brake pedal depressed to hold the car in place during this time. Park the vehicle and allow the brakes to cool to ambient air temperature.

COMPETITION VEHICLES

- If your race car is equipped with brake cooling ducts, blocking them will allow the pads and rotors to warm up quicker and speed up the bedding process.
- Temperature indicating paint on the rotor and pad edges can provide valuable data regarding observed temperatures during the bedding process and subsequent on-track sessions. This information can be highly beneficial when evaluating pad compounds and cooling efficiencies.

POST-BEDDING INSPECTION – ALL VEHICLES

- After the bedding cycle, the rotors should exhibit a uniformly burnished finish across the entire contact face. Any surface irregularities that appear as smearing or splotching on the rotor faces can be an indication that the brakes were brought up to temperature too quickly during the bedding cycle. If the smear doesn't blend away after the next run-in cycle, or if chatter under braking results, sanding or resurfacing the rotors will be required to restore a uniform surface for pad contact.

PRE-RACE WARM UP

- Always make every effort to get heat into the brakes prior to each event. Use an on-and-off the pedal practice to warm the brakes during the trip to the staging zone, during parade laps before the flag drops, and every other opportunity in an effort to build heat in the pads and rotors. This will help to ensure best consistency, performance, and durability from your brakes.

DYNO BEDDED COMPETITION PADS AND ROTORS

- Getting track time for a proper pad and rotor bedding session can be difficult. Wilwood offers factory dyno-bedded pads and rotors on many of our popular competition pads and **Spec 37** GT series rotors. Dyno-bedded parts are ready to race on their first warm up cycle. This can save valuable time and effort when on-track time is either too valuable or not available at all, Dyno-bedding assures that your pads and rotors have been properly run-in and are ready to go. Contact your dealer or the factory for more information on Wilwood Dyno-Bedding services.

NOTE: NEVER allow the contact surfaces of the pads or rotors to be contaminated with brake fluid. Always use a catch bottle with a hose to prevent fluid spill during all brake bleeding procedures.

Parking Brake

WARNING • PARKING BRAKE

- Parking brake must be properly adjusted before use and must be manually readjusted for wear if parking brake handle or foot lever travel becomes excessive.
- The holding ability of the brake should be tested by stopping on a sloping surface and applying the parking brake while holding car with the hydraulic foot brake. This should be accomplished both facing up and down hill.
- Do not rely exclusively on the parking brake to hold the car; Curb wheels as recommended by the applicable diagram and put gear selector in park, or shift into first gear or reverse with a manual transmission.

- Diagram A - When parking facing downhill, turn front wheels towards the curb or right shoulder. This will keep from rolling into traffic if the brakes become disengaged.
- Diagram B - Turn the steering wheel to the left so the wheels are turned towards the road if you are facing uphill with a curb. The tires will catch the curb if the car rolls backward.
- Diagram C - When facing uphill without a curb, turn the wheels sharply to the right. If the vehicle rolls, it will go off the road rather than into traffic.
- When parking on a hill, always set the parking brake and move the gear selector into park, or shift into first or reverse gear if your vehicle has a manual transmission.

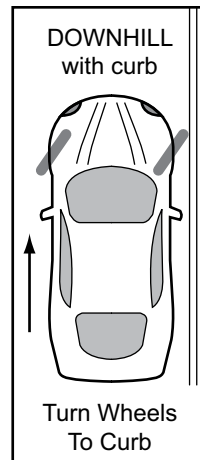

Diagram A

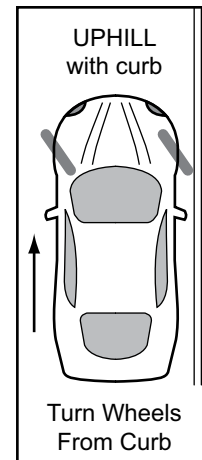

Diagram B

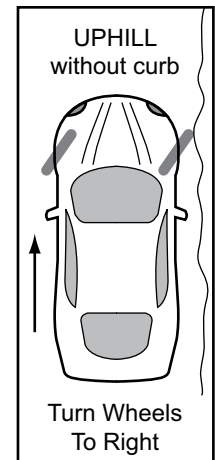

Diagram C

Connect with Wilwood

Wilwood Facebook



Wilwood Instagram



Wilwood Twitter



Wilwood YouTube



Associated Components

<u>PART NO.</u>	<u>DESCRIPTION</u>
260-13706	Wilwood Residual Pressure Valve (2 lb for disc brakes)
260-13707	Wilwood Residual Pressure Valve (10 lb for drum brakes)
260-8419	Wilwood Proportioning Valve, Knob Style
260-8420	Wilwood Proportioning Valve, Lever Style
260-11179	Wilwood Combination Proportioning Valve with Brake Light Switch
290-0632	Wilwood Racing Brake Fluid (Hi-Temp° 570) (12 oz)
290-6209	Wilwood Racing Brake Fluid (EXP 600 Plus) (16.9 oz)
340-13831	Wilwood Floor Mount Brake Pedal (with balance bar)
340-13832	Wilwood Swing Mount Brake Pedal (with balance bar)
260-6764	Wilwood 3/4 inch High Volume Aluminum Master Cylinder
260-6765	Wilwood 7/8 inch High Volume Aluminum Master Cylinder
260-6766	Wilwood 1 inch High Volume Aluminum Master Cylinder
260-4893	1-1/16 inch Tandem Master Cylinder (aluminum housing)
260-8555	Wilwood 1 inch Aluminum Tandem Chamber Master Cylinder
260-8556	Wilwood 1-1/8 inch Aluminum Tandem Chamber Master Cylinder
220-0506	Stainless Steel Braided Flexline Kit, Universal, 14 Inch, Domestic, 3/8-24 IF
220-7699	Stainless Steel Braided Flexline Kit, Universal, 16 Inch, Domestic, 3/8-24 IF
220-8307	Stainless Steel Braided Flexline Kit, Universal, 18 Inch, Domestic, 3/8-24 IF
330-9371	Cable Kit, Parking Brake, Universal