

INSTALLATION INSTRUCTIONS

FOR

**FORWARD FLOOR MOUNT
BRAKE/CLUTCH/THROTTLE
PEDAL ASSEMBLY
WITH BALANCE BAR,
ADJUST. RATIO
PEDALS
(4.75:1 - 5.75:1)***

BASE PART NUMBER

340-16602

OR

**FORWARD FLOOR MOUNT
BRAKE/CLUTCH/THROTTLE
PEDAL ASSEMBLY
WITH BALANCE BAR,
ADJUST. RATIO
PEDALS (4.75:1 - 5.75:1)
AND THROTTLE LINKAGE***

BASE PART NUMBER

340-16603

*For additional vehicle compatibility, visit www.wilwood.com

**DISC BRAKES SHOULD ONLY BE INSTALLED BY SOMEONE
EXPERIENCED AND COMPETENT IN THE INSTALLATION AND
MAINTENANCE OF DISC BRAKES**

READ ALL WARNINGS

WARNING

IT IS THE RESPONSIBILITY OF THE PERSON INSTALLING ANY BRAKE COMPONENT OR KIT TO DETERMINE THE SUITABILITY OF THE COMPONENT OR KIT FOR THAT PARTICULAR APPLICATION. IF YOU ARE NOT SURE HOW TO SAFELY USE THIS BRAKE COMPONENT OR KIT, YOU SHOULD NOT INSTALL OR USE IT. DO NOT ASSUME ANYTHING. IMPROPERLY INSTALLED OR MAINTAINED BRAKES ARE DANGEROUS. IF YOU ARE NOT SURE, GET HELP OR RETURN THE PRODUCT. YOU MAY OBTAIN ADDITIONAL INFORMATION AND TECHNICAL SUPPORT BY CALLING WILWOOD AT (805) 388-1188, OR VISIT OUR WEB SITE AT WWW.WILWOOD.COM. USE OF WILWOOD TECHNICAL SUPPORT DOES NOT GUARANTEE PROPER INSTALLATION. YOU, OR THE PERSON WHO DOES THE INSTALLATION MUST KNOW HOW TO PROPERLY USE THIS PRODUCT. IT IS NOT POSSIBLE OVER THE PHONE TO UNDERSTAND OR FORESEE ALL THE ISSUES THAT MIGHT ARISE IN YOUR INSTALLATION.

RACING EQUIPMENT AND BRAKES MUST BE MAINTAINED AND SHOULD BE CHECKED REGULARLY FOR FATIGUE, DAMAGE, AND WEAR.



Need Additional Information? Use Your
SmartPhone and Jump to Our Technical
Tips Section on Our Web Site.



WARNING

**DO NOT OPERATE ANY VEHICLE ON UNTESTED BRAKES!
SEE MINIMUM TEST PROCEDURE WITHIN**

ALWAYS UTILIZE SAFETY RESTRAINT SYSTEMS AND ALL OTHER AVAILABLE SAFETY EQUIPMENT WHILE OPERATING THE VEHICLE

IMPORTANT • READ THE DISCLAIMER OF WARRANTY INCLUDED IN THE KIT

NOTE: Some cleaners may stain or remove the finish on brake system components. Test the cleaner on a hidden portion of the component before general use.

General Information

FEATURES

- ▶ Pedals have three adjustable ratios ranging from 4.75:1 to 5.75:1
- ▶ Adjustable stainless steel brake and clutch pedal foot pads
- ▶ High strength computer design and lightweight construction
- ▶ High strength steel master cylinder mounting studs
- ▶ Includes brake balance bar and clevises
- ▶ Use with Wilwood compact, high volume, or combination remote master cylinders
- ▶ Easy mounting location
- ▶ Wilwood's own black E-Coat finish
- ▶ Finest quality hardware
- ▶ Keeps master cylinders away from heat source



Pedal Assembly p/n 340-16603 shown

Assembly Instructions

This document is applicable to two pedal assemblies, p/n's 340-16602 and 340-16603. Both pedal assemblies require the customer to do the final assembly of the throttle pedal to the main assembly. Kit p/n 340-16003 requires an additional step of installing the throttle linkage assembly, p/n 340-12412.

P/N 340-16602

NOTE: Numbers in parenthesis refer to the parts list and Figure 1 on page 3.

STEP 1 Slide nylon shim (4) and then throttle pedal (1) onto pivot pin of base assembly. Install pedal return spring (5), then secure using nylon shim (4), wave washer (6), washer (7) and bolt (8), as shown in Figure 1. Apply red *Loctite*[®] 271 and torque to value shown in Figure 1.

STEP 2 Screw the throttle pedal stop bolts (10) into nuts (9) and then into the throttle pedal (1), front and rear. **NOTE:** Final adjustment of the stop bolts will be performed after pedal installation in vehicle.

STEP 3 Screw the clutch stop bolt (12) into nut (11) and then into the clutch pedal, as shown in Figure 1. **NOTE:** Final adjustment of stop bolt will be performed after pedal installation in vehicle.

STEP 4 **NOTE:** For rear engine installation only: Install the rear throttle pull rod (2) to the throttle pedal (1) using bolt (3).

STEP 5 Install pedal heads and foot pad assemblies, see page 5 for detailed instructions.

P/N 340-16603

NOTE: Numbers in parenthesis refer to the parts list and Figure 2 on page 4.

STEP 1 Perform the same throttle pedal assembly procedure as p/n 340-16602 and then add the throttle linkage, p/n 340-12412, as outlined below.

STEP 2 Orient the bell crank assembly as shown in Figure 2 and attach to the pedal base using bolts (10). Apply red *Loctite*[®] 271 to the threads and torque to value shown in Figure 2.

STEP 3 Assemble the connecting rod. Screw jam nut (9) onto male bearing end (8) and then screw the female bearing end (7) onto the male end, Figure 2. Do not tighten jam nut at this time.

STEP 4 Install female bearing end (7) of the connecting rod into throttle pedal using bolt (11), and nut (6), as shown in Figure 2.

STEP 5 Attach the male bearing rod end (8) to the bell crank assembly using bolt (12), three spacers (5), and lock nut (6) as shown in Figure 2. **NOTE:** The bell crank assembly can be set up for a variety of throttle ratios. Final adjustment of the bell crank and connecting rod to be performed after pedal installation in vehicle.

Refer to page 6 and Figure 4 for vehicle installation instructions and mounting dimensions.

Assembly Instructions (Continued)

WARNING
 INSTALLATION OF THIS KIT SHOULD **ONLY** BE PERFORMED BY PERSONS EXPERIENCED IN THE INSTALLATION AND PROPER OPERATION OF DISC BRAKE SYSTEMS.

NOTE
 SPECIFIC PARTS MAY VARY FROM DIAGRAM

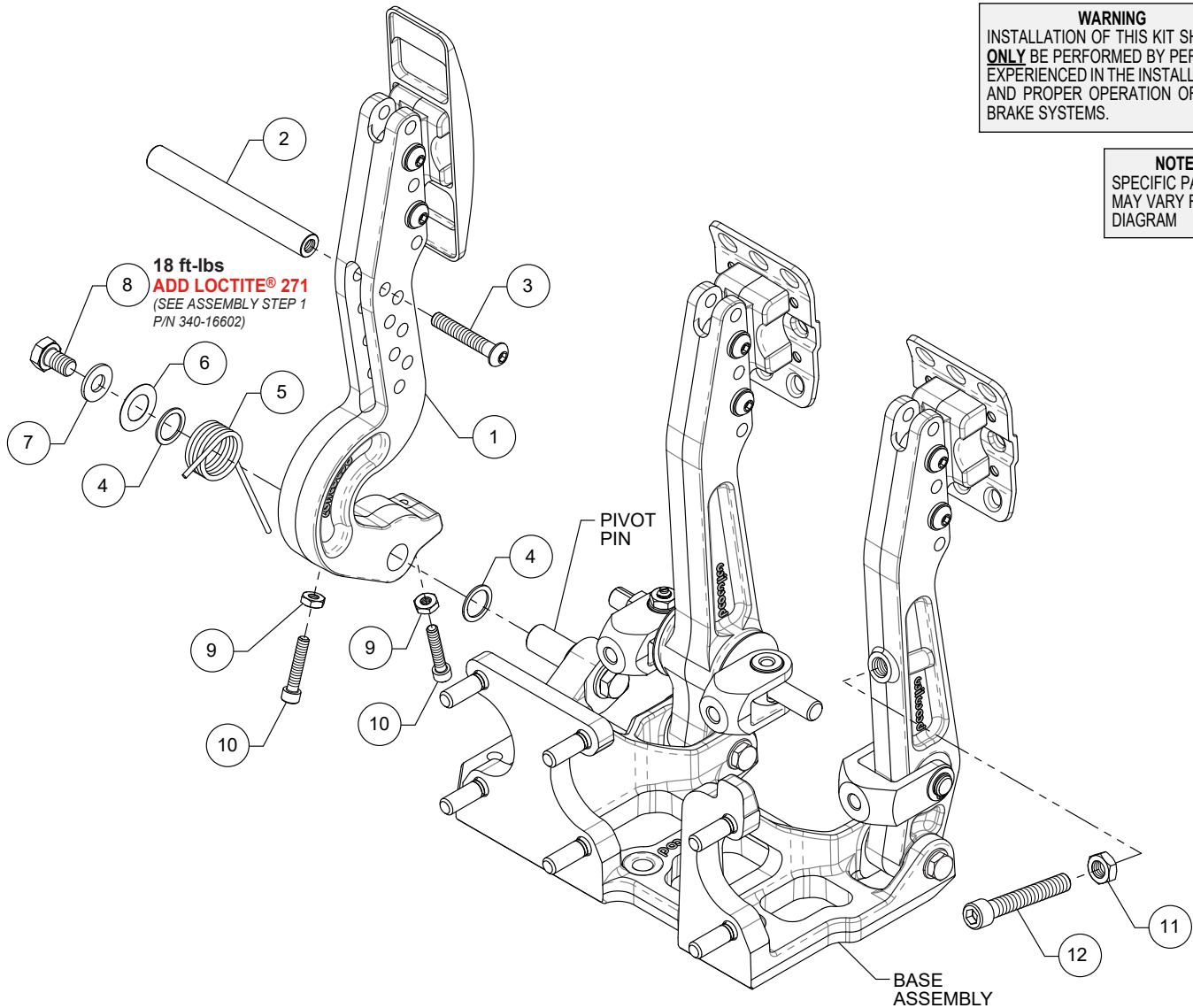

Figure 1. Throttle Pedal Assembly Configuration for Pedal Assembly p/n's 340-16602 and 340-16603

NOTE: Refer to Figure 3 on page 5 for detailed instructions on assembling the pedal pad heads and foot pads

Parts List • Throttle Pedal P/N 340-16602 & P/N 340-16603

ITEM NO.	PART NO.	DESCRIPTION	QTY
1	330-16309X	Pedal, Throttle, Floor Mount	1
2	330-12415	Pull-Rod, Throttle Pedal	1
3	230-12454	Bolt, 1/4-28 x 1.50" Long, Button Head	1
4	240-5047	Shim, .035" Thick, Nylon	2
5	300-16348	Spring, Torsion, Pedal Return	1
6	240-12986	Washer, Wave, .500" I.D. x .870" O.D. x .010" Thick	1
7	240-12451	Washer, .312" I.D. x .730" O.D. x .062" Thick	2
8	230-12450	Bolt, 5/16-24 x .500" Long, Hex Head	2
9	230-16719	Nut, Jam, 10-24, Hex	2
10	230-16714	Bolt, 10-24 x 1.00" Long, Socket Head	2
11	230-1334	Nut, Jam, 5/16-18, Hex	1
12	230-8210	Bolt, 5/16-18 x 2.00" Socket Head	1

Assembly Instructions (Continued)

WARNING
 INSTALLATION OF THIS KIT SHOULD **ONLY** BE PERFORMED BY PERSONS EXPERIENCED IN THE INSTALLATION AND PROPER OPERATION OF DISC BRAKE SYSTEMS.

NOTE
 SPECIFIC PARTS MAY VARY FROM DIAGRAM

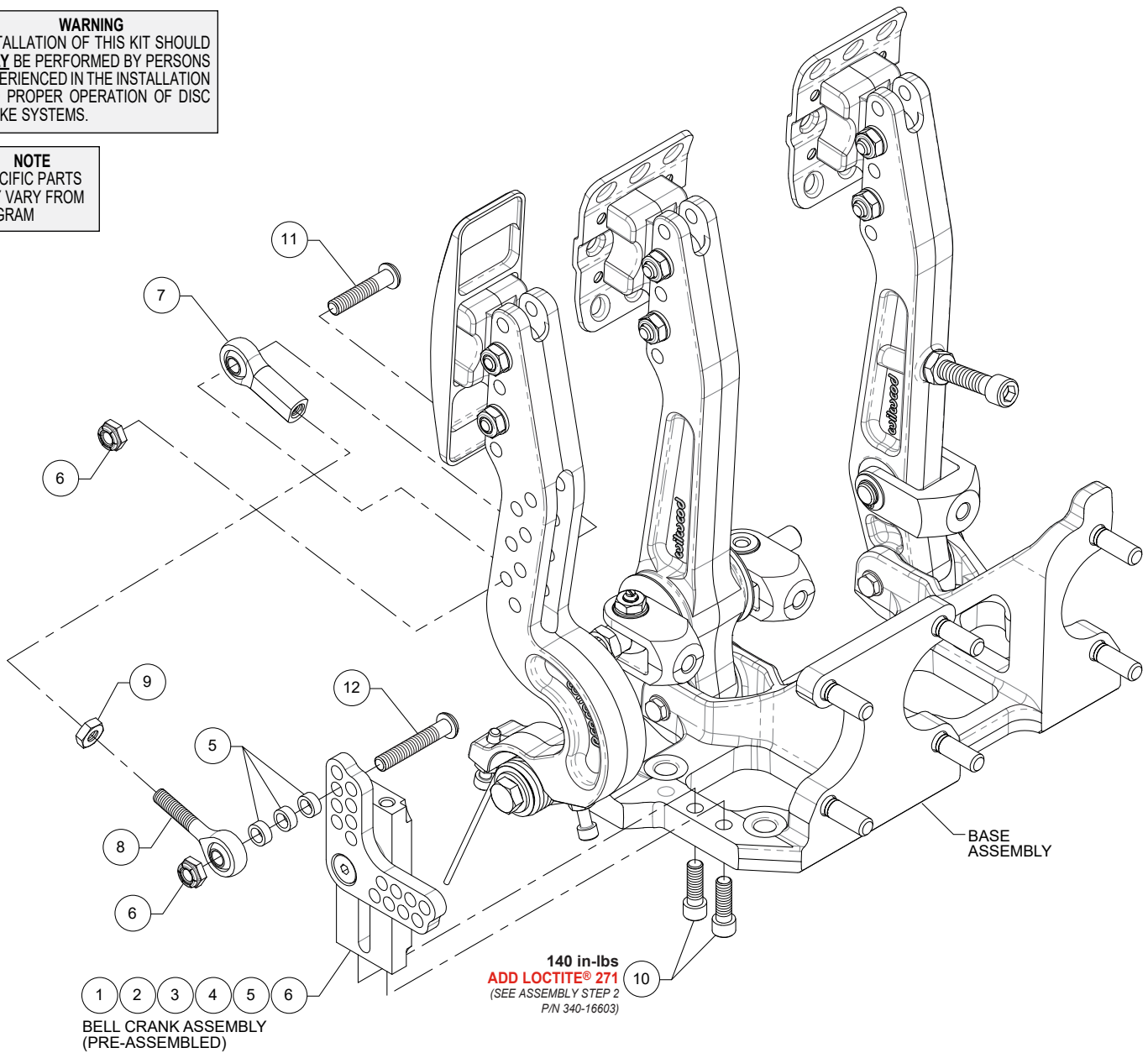

Figure 2. Throttle Linkage Assembly Configuration for Pedal Assembly p/n 340-16603

Parts List • Throttle Linkage P/N 340-12412

ITEM NO.	PART NO.	DESCRIPTION	QTY
1	330-12417	Bell Crank, Throttle Linkage	1
2	330-12416	Housing, Throttle Linkage Assembly	1
3	370-12432	Bearing, .250" I.D. x .688" O.D. x .313" Thick	1
4	230-12456	Bolt, 1/4-28 x 1.00" Long, Flat Head	1
5	300-12418	Spacer, .257" I.D. x .375" O.D. x .155" Long	6
6	230-3774	Nut, Locking, 1/4-28, Hex	3
7	370-12439	Bearing, Rod End, Female	1
8	370-12438	Bearing, Rod End, Male	1
9	230-12457	Nut, Jam, 1/4-28, Hex	1
10	230-0743	Bolt, 1/4-20 x .75" Long, Socket Head	2
11	230-12584	Bolt, 1/4-28 x 1.25" Long, Button Head	1
12	230-12454	Bolt, 1/4-28 x 1.50" Long, Button Head	1

Assembly Instructions (Continued)

Pedal Pad Head and Foot Pad Assembly

STEP 1 Install the pedal pad head (1) into the “fork” of the pedal arm in the desired location as shown in Figure 3. Secure in place using bolts (2), washers (3), and locknuts (4).

STEP 2 Torque locknuts (4) to value indicated in Figure 3.

•NOTE: The position of the pedal head on the lever affects the pedal ratio. Ratio may be adjusted from 4.75:1 to 5.75:1.

STEP 3 Orient foot pad (5) as shown in Figure 3. Pad may be installed in three different positions as shown in Foot Pad Detail of Figure 4, page 6 (not applicable to throttle foot pad). Secure to pedal head (1) using four T-20 drive Torx screws (6). Apply blue *Loctite*® 242 to the threads and torque to value indicated in Figure 3.

STEP 4 Apply grip tape sticker (8) to throttle foot pad (7) (both not shown) after attaching foot pad to pedal head.

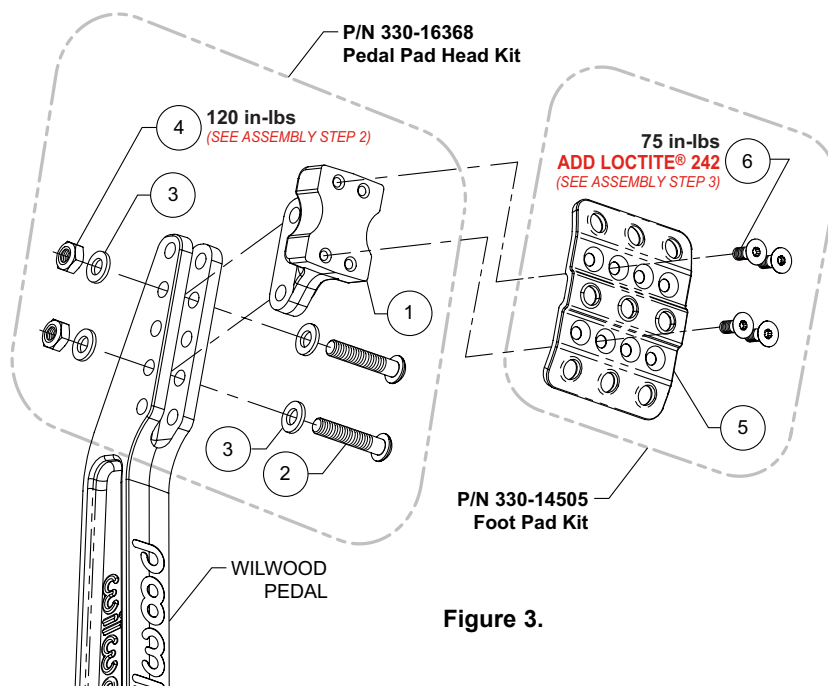

Figure 3.

ITEM NO.	PART NO.	DESCRIPTION	QTY	NOTES
1	330-16077	Pedal Pad Head, Adjustable	3	P/N 330-16368 Pedal Head Kit, includes p/n's 230-16369, 230-16370, 240-11240, and 330-16077
2	230-16369	Bolt, 1/4-28 x 1.25" Long, Button Head	6	
3	240-11240	Washer, .265" I.D. x .500" O.D. x .063" Thick	12	
4	230-16370	Nut, 1/4-28, Nylock	6	P/N 330-14505 Foot Pad Kit, includes p/n's 230-11300, and 330-11280
5	330-11280	Foot Pad, Adjustable, Brake & Clutch	2	
6	230-11300	Screw, 10-24 x .50" Long, T-20 Torx Drive	12	P/N 330-16609 Throttle Foot Pad Kit, includes p/n's 230-11300, 330-16310x, and 400-12507
7	330-16310x	Foot Pad, Throttle (not shown)	1	
8	400-12507	Grip Tape Sticker, Foot Pad, Throttle (not shown)	1	

Installation and Adjustment Instructions

Installation of this component should **ONLY** be performed by persons experienced in the installation and proper operation of disc brake systems. Before assembly begins, familiarize yourself with the following procedure to ensure a trouble-free installation.

•Mount the final pedal assembly to the floor using six .34" through holes as shown in Figure 4. Attach the pedal assembly to sturdy beams or plates with six 5/16" bolts. Pedal assembly must be rigidly attached to frame and not deflect under heavy pedal forces. **NOTE:** Pedals must be free from obstructions over their entire range of motion. Allow enough space so balance bar adjustments can be made and master cylinders are accessible.

Adjustments:

•Throttle pedal apply and return limits can be adjusted via the bottom front (as it sits in the vehicle) and bottom rear stop screws on the pedal. Adjust screws to achieve desired pedal position and lock in place with nuts.

•Clutch pedal position adjustment is made by turning the pushrod in and out of the clevis. The hard stop can be adjusted to limit the clutch pedal travel, if desired, and locked in place with the nut.

•Brake pedal position is adjusted via the pushrods in the balance bar clevises. Refer to our data sheet DS-252 (available at www.wilwood.com/PDF/DataSheets/ds252.pdf) for proper balance bar adjustment procedure.

•The optional throttle linkage may be set up and adjusted to accommodate most any application. After setting the pedal stops, remove the connecting rod from the bell crank and turn the rod end in or out to adjust its length, and lock in position with nut. Reconnect the rod end to the bell crank in the desired hole location. Connect the throttle cable end (customer supplied) to the desired hole location in the other half of the bell crank.

•Attaching the connecting rod and throttle cable end to equal opposing holes on the bell crank will not affect the throttle pedal ratio. Moving the cable end closer to the bell crank pivot will increase the effective pedal ratio and decrease the available cable travel. Moving the connecting rod closer to the pivot will have the opposite effect.

Physical Dimensions

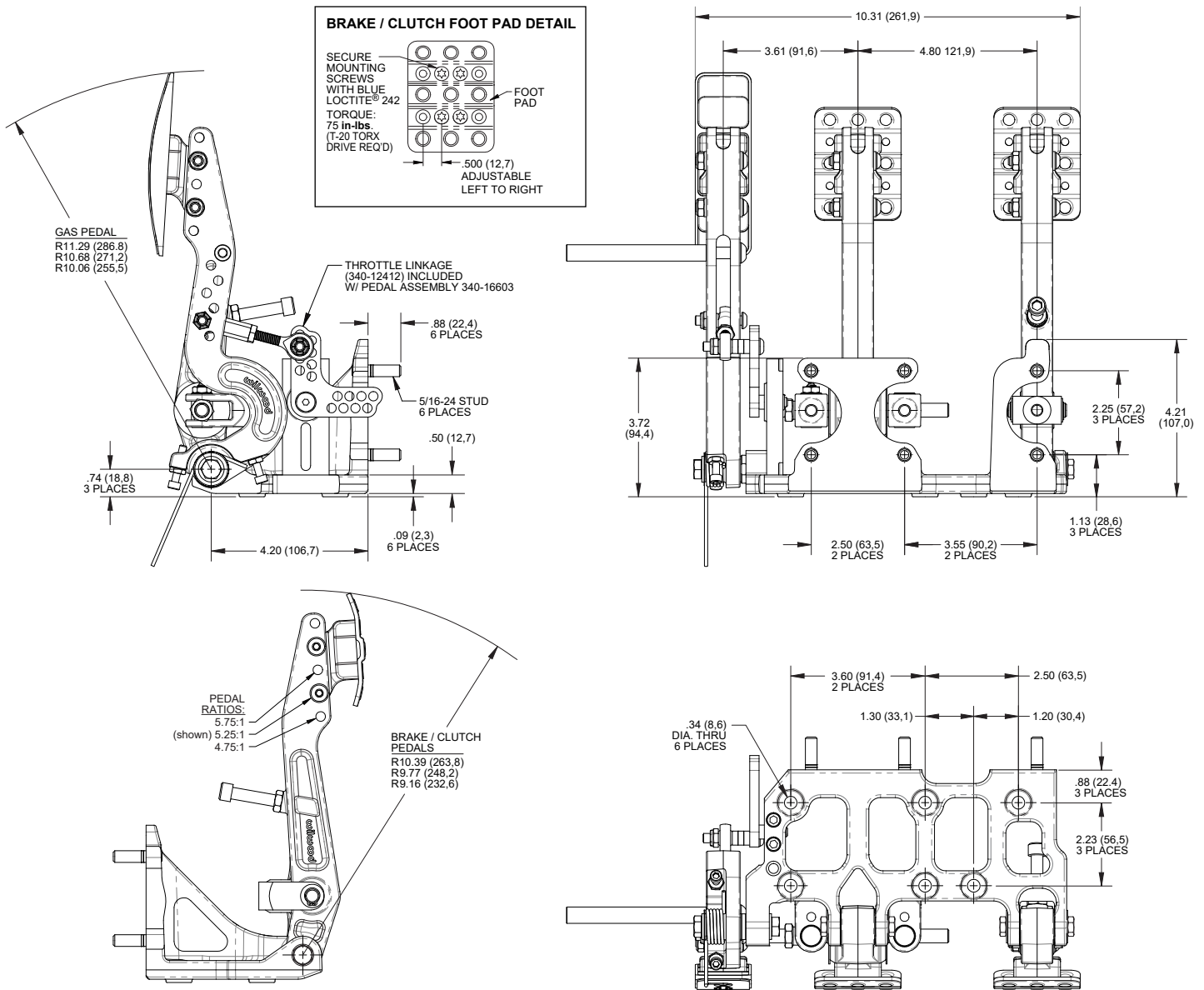

Figure 4. Forward Mount Triple Pedal Assembly, Physical Dimensions, 4.75:1 to 5.75:1 Adjustable Ratios (p/n's 340-16602 & 340-16603)

Additional Information and Recommendations

- The pedal assembly uses standard racing master cylinder mounting patterns. Wilwood's compact, high volume, and combination remote master cylinders mount directly to the pedal assembly, as do most other high performance master cylinders. All master cylinder mounting hardware is included with the pedal assembly. Master cylinder flange should mount flush to pedal assembly and be held in place with enclosed washers and locknuts. The clevis on brake and clutch pedal has a 5/16-24 thread. Make sure to use a jam nut on the master cylinder pushrod when threaded into clevis and check that pushrod is allowed to fully retract when pedal is released.
- Wilwood Hi-Temp[®] 570 Racing Brake Fluid (6 pack P/N 290-2210) is recommended for race cars and high performance vehicles where brake temperatures exceed normal operating conditions, or use Wilwood EXP 600 Plus Super Hi-Temp (6 pack P/N 290-8478) for severe conditions. For extreme braking temperatures of endurance racing, use Wilwood XR Race-Only Brake Fluid (4 pack P/N 290-16354, not DOT approved, off-highway use only). Used fluid must be completely flushed from the system to prevent contamination. **NOTE: Silicone DOT 5 brake fluid is NOT recommended for racing or performance driving.**
- If after following the instructions, you still have difficulty in assembling your Wilwood floor mount triple pedal assembly, consult your local chassis builder, or retailer where the component was purchased for further assistance.

Brake Testing

WARNING • DO NOT DRIVE ON UNTESTED BRAKES BRAKES MUST BE TESTED AFTER INSTALLATION OR MAINTENANCE MINIMUM TEST PROCEDURE

- Make sure pedal is firm: Hold firm pressure on pedal for several minutes, it should remain in position without sinking. If pedal sinks toward floor, check system for fluid leaks. DO NOT drive vehicle if pedal does not stay firm or can be pushed to the floor with normal pressure.
- At very low speed (2-5 mph) apply brakes hard several times while turning steering from full left to full right, repeat several times. Remove the wheels and check that components are not touching, rubbing, or leaking.
- Carefully examine all brake components, brake lines, and fittings for leaks and interference.
- Make sure there is no interference with wheels or suspension components.
- Drive vehicle at low speed (15-20 mph) making moderate and hard stops. Brakes should feel normal and positive. Again check for leaks and interference.
- Always test vehicle in a safe place where there is no danger to (or from) other people or vehicles.
- Always wear seat belts and make use of all safety equipment.

Pad and Rotor Bedding

BEDDING STEPS FOR NEW PADS AND ROTORS – ALL COMPOUNDS

Once the brake system has been tested and determined safe to operate the vehicle, follow these steps for the bedding of all new pad materials and rotors. These procedures should only be performed on a race track, or other safe location where you can safely and legally obtain speeds up to 65 MPH, while also being able to rapidly decelerate.

- Begin with a series of light decelerations to gradually build some heat in the brakes. Use an on-and-off the pedal technique by applying the brakes for 3-5 seconds, and then allow them to fully release for a period roughly twice as long as the deceleration cycle. If you use a 5 count during the deceleration interval, use a 10 count during the release to allow the heat to sink into the pads and rotors.
- After several cycles of light stops to begin warming the brakes, proceed with a series of medium to firm deceleration stops to continue raising the temperature level in the brakes.
- Finish the bedding cycle with a series of 8-10 hard decelerations from 55-65 MPH down to 25 MPH while allowing a proportionate release and heat-sinking interval between each stop. The pads should now be providing positive and consistent response.
- If any amount of brake fade is observed during the bed-in cycle, immediately begin the cool down cycle.
- Drive at a moderate cruising speed, with the least amount of brake contact possible, until most of the heat has dissipated from the brakes. Avoid sitting stopped with the brake pedal depressed to hold the car in place during this time. Park the vehicle and allow the brakes to cool to ambient air temperature.

COMPETITION VEHICLES

- If your race car is equipped with brake cooling ducts, blocking them will allow the pads and rotors to warm up quicker and speed up the bedding process.
- Temperature indicating paint on the rotor and pad edges can provide valuable data regarding observed temperatures during the bedding process and subsequent on-track sessions. This information can be highly beneficial when evaluating pad compounds and cooling efficiencies.

Pad and Rotor Bedding (Continued)

POST-BEDDING INSPECTION – ALL VEHICLES

•After the bedding cycle, the rotors should exhibit a uniformly burnished finish across the entire contact face. Any surface irregularities that appear as smearing or splotching on the rotor faces can be an indication that the brakes were brought up to temperature too quickly during the bedding cycle. If the smear doesn't blend away after the next run-in cycle, or if chatter under braking results, sanding or resurfacing the rotors will be required to restore a uniform surface for pad contact.

PRE-RACE WARM UP

•Always make every effort to get heat into the brakes prior to each event. Use an on-and-off the pedal practice to warm the brakes during the trip to the staging zone, during parade laps before the flag drops, and every other opportunity in an effort to build heat in the pads and rotors. This will help to ensure best consistency, performance, and durability from your brakes.

DYNO BEDDED COMPETITION PADS AND ROTORS

•Getting track time for a proper pad and rotor bedding session can be difficult. Wilwood offers factory dyno-bedded pads and rotors on many of our popular competition pads and **Spec 37** GT series rotors. Dyno-bedded parts are ready to race on their first warm up cycle. This can save valuable time and effort when on-track time is either too valuable or not available at all, Dyno-bedding assures that your pads and rotors have been properly run-in and are ready to go. Contact your dealer or the factory for more information on Wilwood Dyno-Bedding services.

NOTE: NEVER allow the contact surfaces of the pads or rotors to be contaminated with brake fluid. Always use a catch bottle with a hose to prevent fluid spill during all brake bleeding procedures.

Connect with Wilwood

Wilwood Facebook



Wilwood Instagram



Wilwood Twitter



Wilwood YouTube



Associated Components

<u>PART NO.</u>	<u>DESCRIPTION</u>
260-5920	Wilwood Combination Remote Master Cylinder, 13/16" bore
260-6764	Wilwood High Volume Master Cylinder, 3/4" bore
260-10371	Wilwood Compact Remote Master Cylinder, 5/8" bore
260-13706	Wilwood Residual Pressure Valve (2 lb for disc brakes)
260-13707	Wilwood Residual Pressure Valve (10 lb for drum brakes)
260-8419	Wilwood Proportioning Valve, Knob Style
260-8420	Wilwood Proportioning Valve, Lever Style
260-11179	Wilwood Combination Proportioning Valve with Brake Light Switch
290-0632	Wilwood Racing Brake Fluid (Hi-Temp° 570) (12 oz)
290-6209	Wilwood Racing Brake Fluid (EXP 600 Plus) (16.9 oz)
290-16353	Wilwood Racing Brake Fluid (XR Race-Only) (16.9 oz)