

LIGHTWEIGHT MASTER CYLINDER FLUID RESERVOIRS

LIGHTWEIGHT RESERVOIR MOUNTING BRACKETS

SPECIFICATION SHEET & INSTRUCTIONS

Reservoir Kit Part Numbers

260-16389 • 260-16390
260-16391 • 260-16392



Direct Mount
P/N
260-16389
with 9/16-18
to 11/16-20
thread adapter

Remote Mount
P/N
260-16390
with 9/16-18
to -3 AN hose
connector

Direct Mount
P/N
260-16391
with 9/16-18
to 11/16-20
thread adapter

Remote Mount
P/N
260-16392
with 9/16-18
to -3 AN hose
connector

General Information - Reservoirs

•Part numbers 260-16389 (billet finish) and 260-16391 (anodized finish) are direct mount lightweight billet aluminum 4 ounce reservoirs designed specifically to mount to Wilwood's flange or side mount compact short master cylinders via the 11/16-20 internally threaded reservoir support. Master cylinder part numbers 260-10371 thru 260-10376 and 260-12384 thru 260-12389. *(Continued on next page)*

Bracket Kit Part Numbers

250-16871 • 250-16872 • 250-16327
250-16393 • 250-16873 • 250-16874



Single Reservoir Lightweight Bracket

P/N 250-16871: Billet finish aluminum bracket w/ mounting screws
P/N 250-16872: Anodized aluminum bracket w/ mounting screws (shown)



Dual Reservoir Lightweight Bracket

P/N 250-16327: Billet finish aluminum bracket w/ mounting screws (shown)
P/N 250-16393: Anodized aluminum bracket w/ mounting screws



Triple Reservoir Lightweight Bracket

P/N 250-16873: Billet finish aluminum bracket w/ mounting screws
P/N 250-16874: Anodized aluminum bracket w/ mounting screws (shown)

WARNING

THIS COMPONENT IS DESIGNED FOR USE IN CUSTOM BRAKE SYSTEMS ON PERFORMANCE, RACING, AND OTHER SPECIAL PURPOSE BUILT OFF-ROAD VEHICLES. IT IS NOT INTENDED AS A DIRECT REPLACEMENT FOR ANY OEM APPLICATION.

General Information (Cont.)

•Part numbers 260-16390 (billet finish) and 260-16392 (anodized finish) are remote mount billet aluminum 4 ounce reservoirs designed specifically to mount away from the master cylinder body using a mounting bracket (sold separately). Connection to the master cylinder is via the 3/8-24 thread -3 AN fluid fitting and a -3 AN flexline.



Decorative sleeve and o-ring for master cylinder included.

- For all of the applications mentioned, install o-ring and decorative sleeve on master cylinder before installing inlet fitting.
- To order flexlines to connect the reservoir to the master cylinder, see below for part numbers.
- For mounting dimensions of reservoirs and brackets, see Figures 1 thru 5.

Master Cylinder Installation

•**NOTE: If replacing the stock master cylinder, additional brake line plumbing may be required.**

•Fill the reservoir(s) to the bottom of the neck with Wilwood brake fluid from a new, sealed container and purge any air from the master cylinder. Be sure the cylinder is level during the bleeding operation. If the cylinder is not level when mounted in the vehicle, bench bleed the master cylinder prior to installation to its vehicle mount. Exercise care to not spill or spray brake fluid. Take all proper safety precautions including eye and skin protection and do not position your face directly above the reservoir. This process will assure a quick and effective full system bleed later.

•Once all fluid connections have been made, the complete system must be bled and checked for leaks prior to any test of the vehicle.

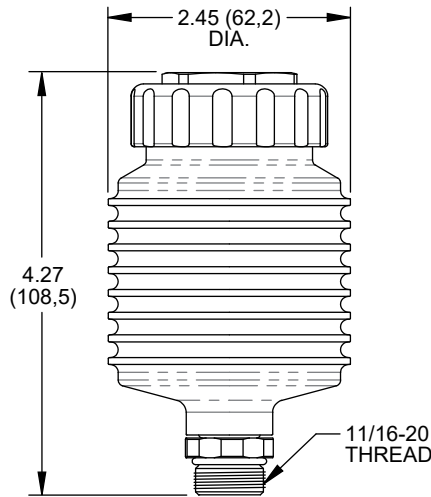

Figure 1.
P/N 260-16389 & 260-16391
Fluid Reservoir
Mounting Dimensions

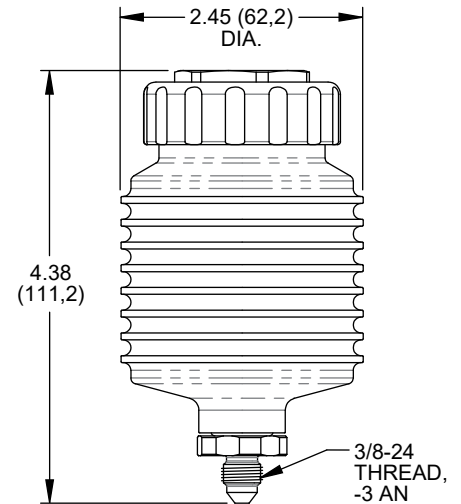

Figure 2.
P/N 260-16390 & 260-16392
Fluid Reservoir
Mounting Dimensions

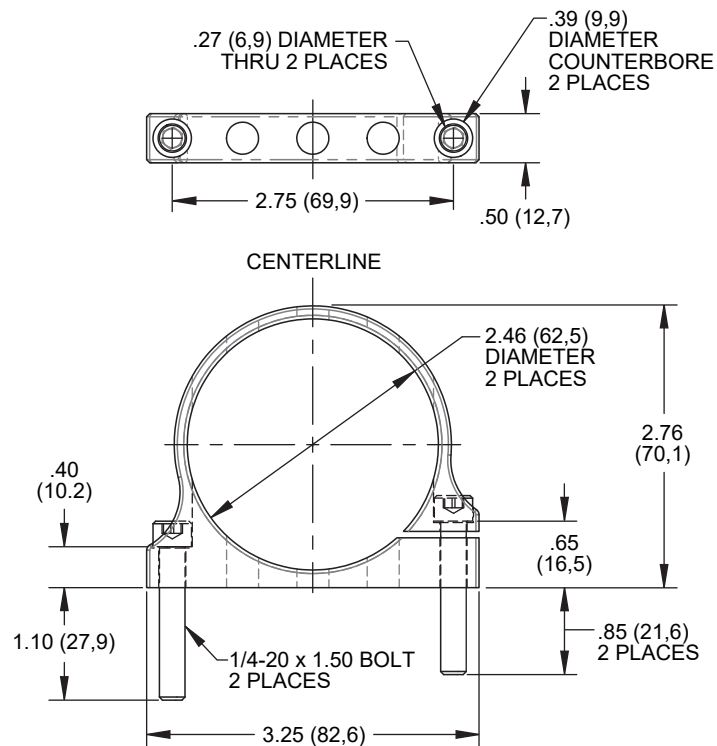

Figure 3.
P/Ns 250-16871 & 250-16872
Single Reservoir Mounting Bracket Dimensions

Remote Reservoir Flexline Kits

Part No.	Description
220-12992	6.00 Inch Long -3 AN Stainless Steel Flexline with -3 AN to 11/16-20 Remote Inlet Adapter
220-12993	8.00 Inch Long -3 AN Stainless Steel Flexline with -3 AN to 11/16-20 Remote Inlet Adapter
220-13004	10.00 Inch Long -3 AN Stainless Steel Flexline with -3 AN to 11/16-20 Remote Inlet Adapter
220-13005	12.00 Inch Long -3 AN Stainless Steel Flexline with -3 AN to 11/16-20 Remote Inlet Adapter

Plumbing & Precautions

- Use of reinforced flexible lines should be limited to the connection between the remote fluid reservoir and master cylinder, and between the fixed chassis and the moving suspension. All other lines along the fixed chassis should be hard steel lines.
- On four wheel disc brake applications, where the fluid reservoir is mounted higher than the caliper bleed screws, a residual pressure valve is usually not required.
- Disc brake applications where the fluid reservoir is mounted lower than the caliper bleed screws may require a 2-pound residual pressure valve. This can prevent fluid drain back and excessive pedal travel on initial engagement.
- Use an adjustable proportioning valve to set the front to rear brake bias.

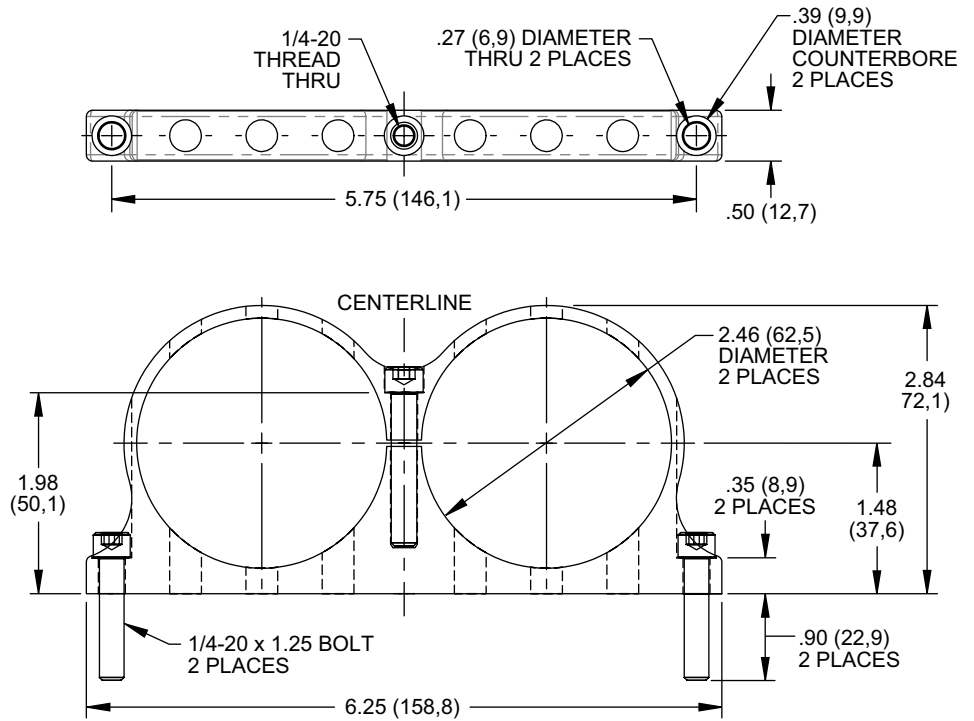

Figure 4.
P/Ns 250-16327 & 250-16393
Dual Reservoir Mounting Bracket Dimensions

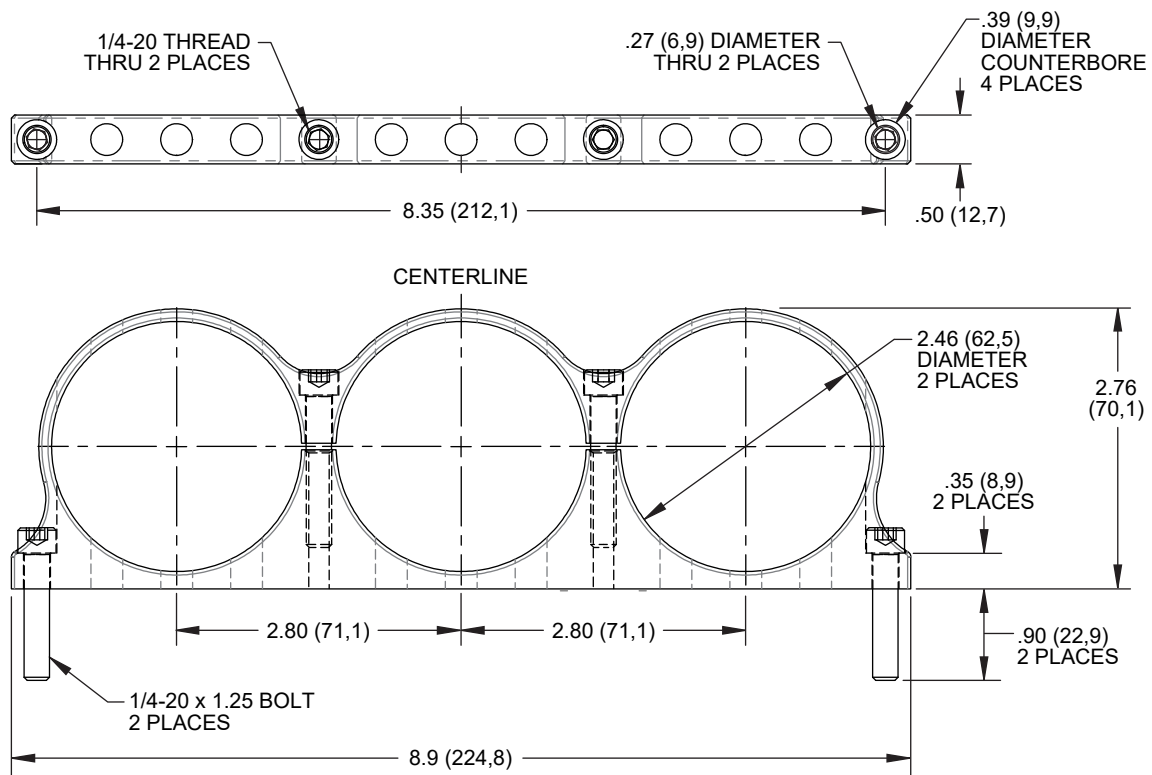

Figure 5.
P/Ns 250-16873 & 250-16874
Triple Reservoir Mounting Bracket Dimensions

Associated Components

<u>Part No.</u>	<u>Description</u>	<u>Part No.</u>	<u>Description</u>
220-12942	9/16-18 to -3 AN, Remote Mount Reservoir Fitting	290-0632	Wilwood Hi-Temp 570 DOT 3 Fluid
220-12943	11/16-20 to 9/16-18, Direct Mount Reservoir Fitting	290-6209	Wilwood EXP 600 Plus Super Hi-Temp Fluid
220-13130	11/16-20 to -3 AN male, M/C Brake Line Fitting	290-16353	Wilwood XR Race-Only Extreme Hi-Temp Fluid
220-14909	11/16-20 to 1/8-27 female, M/C Brake Line Fitting	330-12954	Billet Finish Reservoir Cap, Vented Diaphragm
250-12701	Bracket, Single 4 oz. Reservoir Mount, Billet	330-16239	Black Nylon Reservoir Cap, Vented Diaphragm

Brake Testing

WARNING • DO NOT DRIVE ON UNTESTED BRAKES BRAKES MUST BE TESTED AFTER INSTALLATION OR MAINTENANCE MINIMUM TEST PROCEDURE

- Make sure pedal is firm: Hold firm pressure on pedal for several minutes, it should remain in position without sinking. If pedal sinks toward floor, check system for fluid leaks. DO NOT drive vehicle if pedal does not stay firm or can be pushed to the floor with normal pressure.
- At very low speed (2-5 mph) apply brakes hard several times while turning steering from full left to full right, repeat several times. Remove the wheels and check that components are not touching, rubbing, or leaking.
- Carefully examine all brake components, brake lines, and fittings for leaks and interference.
- Make sure there is no interference with wheels or suspension components.
- Drive vehicle at low speed (15-20 mph) making moderate and hard stops. Brakes should feel normal and positive. Again check for leaks and interference.
- Always test vehicle in a safe place where there is no danger to (or from) other people or vehicles.
- Always wear seat belts and make use of all safety equipment.

WARNING

IT IS THE RESPONSIBILITY OF THE PERSON INSTALLING ANY BRAKE COMPONENT OR KIT TO DETERMINE THE SUITABILITY OF THE COMPONENT OR KIT FOR THAT PARTICULAR APPLICATION. IF YOU ARE NOT SURE HOW TO SAFELY USE THIS BRAKE COMPONENT OR KIT, YOU SHOULD NOT INSTALL OR USE IT. DO NOT ASSUME ANYTHING. IMPROPERLY INSTALLED OR MAINTAINED BRAKES ARE DANGEROUS. IF YOU ARE NOT SURE, GET HELP OR RETURN THE PRODUCT. YOU MAY OBTAIN ADDITIONAL INFORMATION AND TECHNICAL SUPPORT BY CALLING WILWOOD AT (805) 388-1188, OR VISIT OUR WEB SITE AT WWW.WILWOOD.COM. USE OF WILWOOD TECHNICAL SUPPORT DOES NOT GUARANTEE PROPER INSTALLATION. **YOU**, OR THE PERSON WHO DOES THE INSTALLATION MUST KNOW HOW TO PROPERLY USE THIS PRODUCT. IT IS NOT POSSIBLE OVER THE PHONE TO UNDERSTAND OR FORESEE ALL THE ISSUES THAT MIGHT ARISE IN YOUR INSTALLATION.

RACING EQUIPMENT AND BRAKES MUST BE MAINTAINED AND SHOULD BE CHECKED REGULARLY FOR FATIGUE, DAMAGE, AND WEAR.