

## LUG-DRIVE DYNAMIC-MOUNT SX6R FRONT & AERO4 REAR BIG BRAKE KITS for C8 CORVETTE

Wilwood's Speed Xtreme **SX6R** six piston front and Aerolite **AERO4** four piston rear calipers are combined with 15.00" dynamic-mount, **Lug-Drive** floating rotors to create the ultimate C8 Corvette big brake package. These rotors are more than 2" larger in diameter than the base model's brakes, 1.7" larger than the factory Z51, and 0.5" larger than the Z06. The kits deliver better pedal feel, increased brake torque, and greater thermal capacity without distortion.

### KIT FEATURES:

- Complete bolt-on installation that works with the factory master cylinder and on-board computers without modification
- Increased thermal capacity for heavy use without fading or distortion

### FRONT CALIPERS: SX6R

- Strong and rigid stress flow forged aluminum SX6R caliper body with closed central bridge resists deflection for better pedal feel and improved clamping
- Six stainless steel pistons in Type-III hard anodized bores with high-temperature seals for durability

### REAR CALIPERS: AERO4 with EPB

- Rigid stress flow forged aluminum Aerolite four piston caliper sized to maintain proper brake bias
- EPB parking brake caliper works with factory switch and on-board computers

SX6R Front with  
SRP Drilled & Slotted Rotor  
[P/N 140-17004-DR](#)



**EPB**  
Electric Park Brake  
Included in rear kit.  
Integrates with  
factory system.

AERO4 Rear with  
GT Slotted Rotor / EPB  
[P/N 140-17009](#)



### Lug-Drive Dynamic-Mount Technology

**Spec37** Alloy 72 Curved Vane  
Directional Rotor

Forged Aluminum  
Hat with Type-III  
Hard Ano Finish

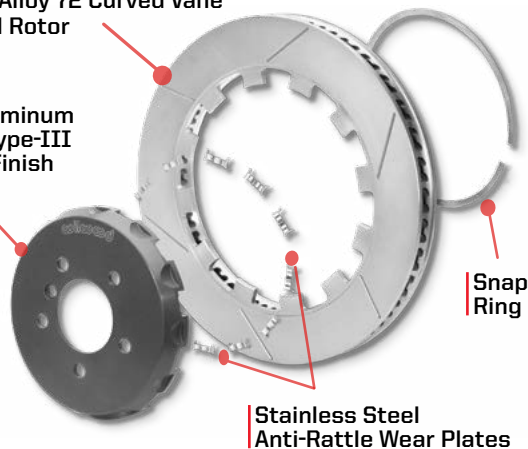

### ROTORS: **Spec37** GT or SRP DRILLED

- Dynamic-mount **Lug-Drive** floating rotor system isolates thermally induced stresses between the hat and rotor
- Race-proven **Lug-Drive** system eliminates need for safety wire, thread lockers, or torque wrenches
- Big 15.00" **Spec37** 72 curved vane rotors have more thermal capacity and better cooling for increased performance and longer life; choose GT slotted or SRP drilled & slotted

### BRAKE PADS: BP-10

- BP-10 street performance pads provide smooth, and consistent response with long wear over a broad range of temperatures (other compounds available)

### INSTALLATION PARTS:

- Caliper brackets, stainless steel braided Flexlines, and premium-grade installation hardware included

# wilwood DISC BRAKES

## C8 CHEVY CORVETTE

2020-2023

### SX6R/AERO4 15" LUG-DRIVE FRONT & REAR BIG BRAKE KITS

#### SX6R Front Kits SRP Drilled & Slotted Rotors



#### Typical Installation Diagram - Front

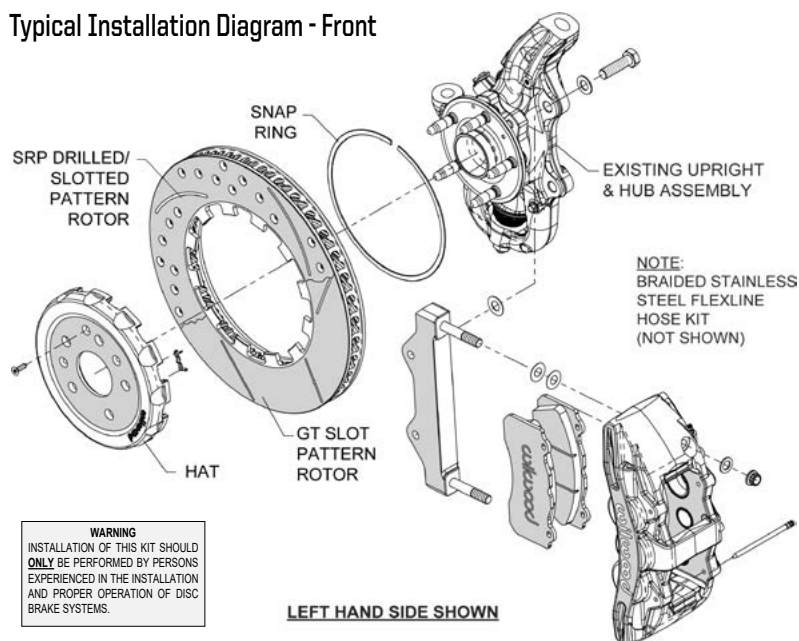

#### SX6R Front Kits GT Slotted Rotors



#### AERO4 Rear Kits SRP Drilled & Slotted Rotors

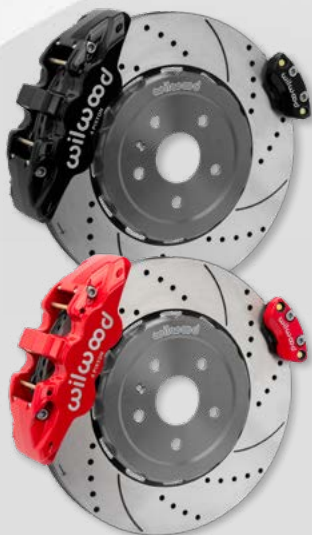

#### Typical Installation Diagram - Rear

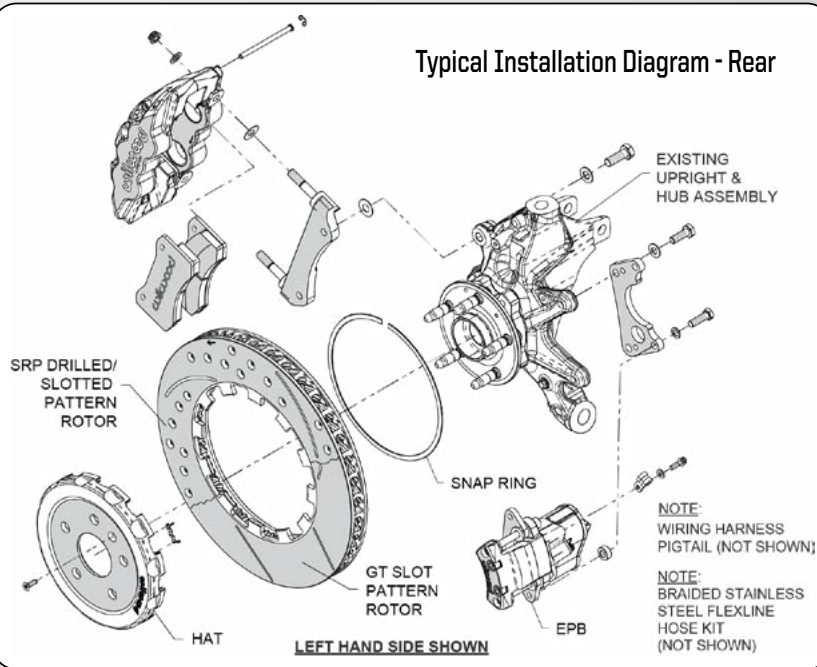

#### AERO4 Rear Kits GT Slotted Rotors



ORDERING INFORMATION: PH: 805.388.1188 • FAX: 805.388.4938 • [wilwood.com](http://wilwood.com) • [info@wilwood.com](mailto:info@wilwood.com)

| BLACK                       | RED                          | DESCRIPTION                                    | CALIPER TYPE             | ROTOR TYPE                                    | ROTOR SIZE     |
|-----------------------------|------------------------------|--|--------------------------|---|----------------|
| <a href="#">140-17004</a>   | <a href="#">140-17004-R</a>  | Kit, Front SX6R Lug-Drive, 2020-23 C8 Corvette | Street Xtreme, 6 piston  | GT Slotted, 72 Curved Vane, Spec37            | 15.00" x 1.25" |
| <a href="#">140-17004-D</a> | <a href="#">140-17004-DR</a> | Kit, Front SX6R Lug-Drive, 2020-23 C8 Corvette | Street Xtreme, 6 piston  | SRP Drilled & Slotted, 72 Curved Vane, Spec37 | 15.00" x 1.25" |
| <a href="#">140-17009</a>   | <a href="#">140-17009-R</a>  | Kit, Rear Aero4 Lug-Drive, 2020-23 C8 Corvette | Aerolite, 4 piston + EPB | GT Slotted, 72 Curved Vane, Spec37            | 15.00" x 1.25" |
| <a href="#">140-17009-D</a> | <a href="#">140-17009-DR</a> | Kit, Rear Aero4 Lug-Drive, 2020-23 C8 Corvette | Aerolite, 4 piston + EPB | SRP Drilled & Slotted, 72 Curved Vane, Spec37 | 15.00" x 1.25" |