

**DYNAPRO DRAG RACE FRONT
BRAKE KITS** use Wilwood's
lightweight dynamic
mount floating rotor
system to eliminate
rotor distortion and
speed-robbing drag
during repeated
high-heat stops
on high-MPH,
full-body drag
race-only vehicles.

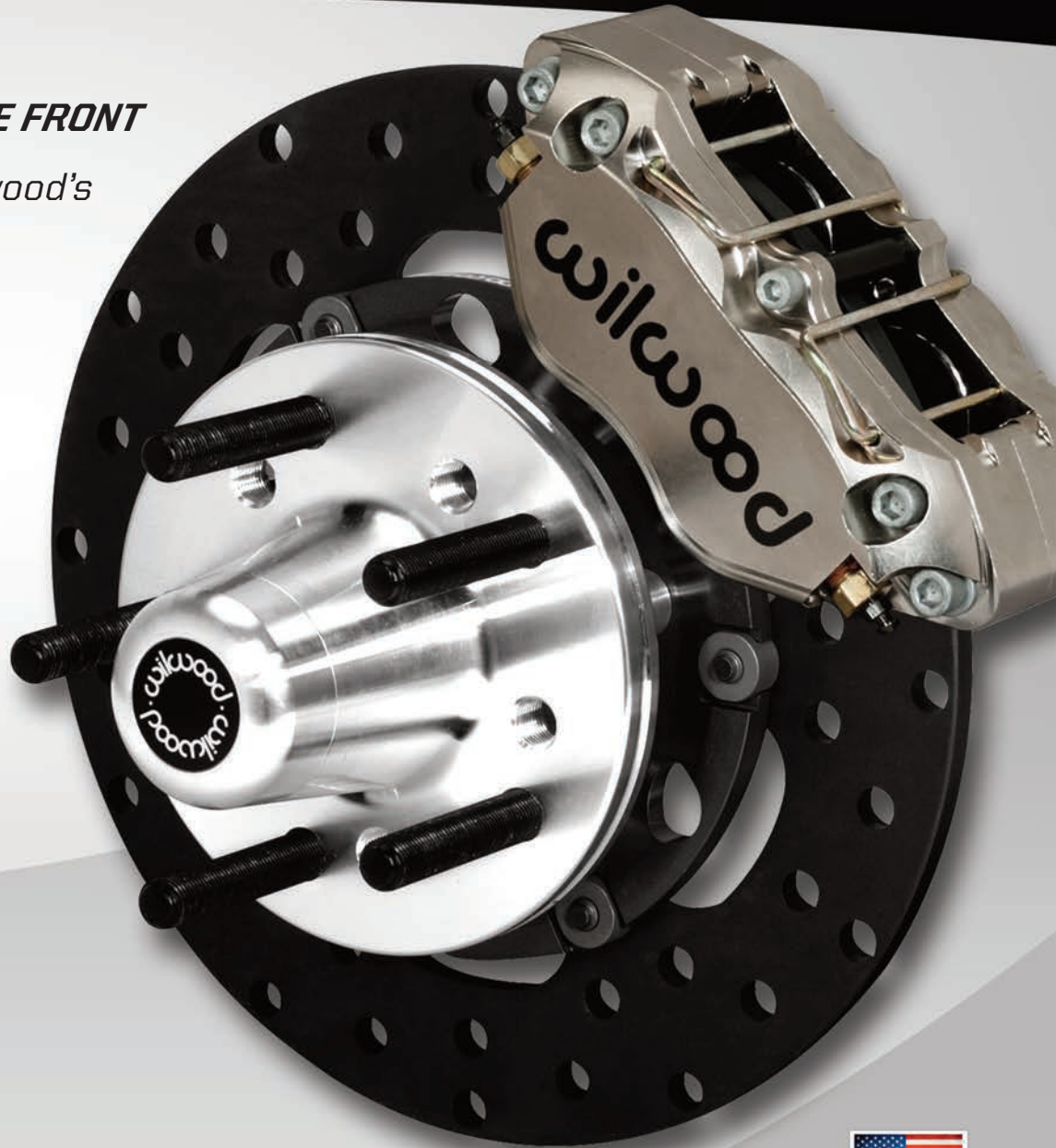

KIT FEATURES



- DynaPro four piston lug mount calipers and brackets mount directly to the OE spindles
- High-response, fade-resistant BP-20 compound *SmartPads*
- Controlled pad release and flatter rotors reduce drag
- Floating rotors eliminate distortion that occurs with fixed mount rotors after repeated high heat cycles
- Drilled steel alloy rotors weigh only 4.7 pounds each
- Hard-coat anodized aluminum rotor mount plates with t-nuts
- Lightweight forged aluminum hubs with extended length 1/2-20 grade 8 wheel studs
- Complete kits include all new wheel bearings, hub seals and premium grade hardware
- Braided stainless steel DOT-type flexlines available separately

Note: Check www.wilwood.com for complete year/make/model application data and specific wheel clearance requirements.

DYNAPRO DRAG RACE FRONT DISC BRAKE KITS

PLEASE CHECK: WILWOOD ALWAYS RECOMMENDS CHECKING www.wilwood.com FOR COMPLETE YEAR/MAKE/MODEL APPLICATION DATA AND SPECIFIC WHEEL CLEARANCE REQUIREMENTS.

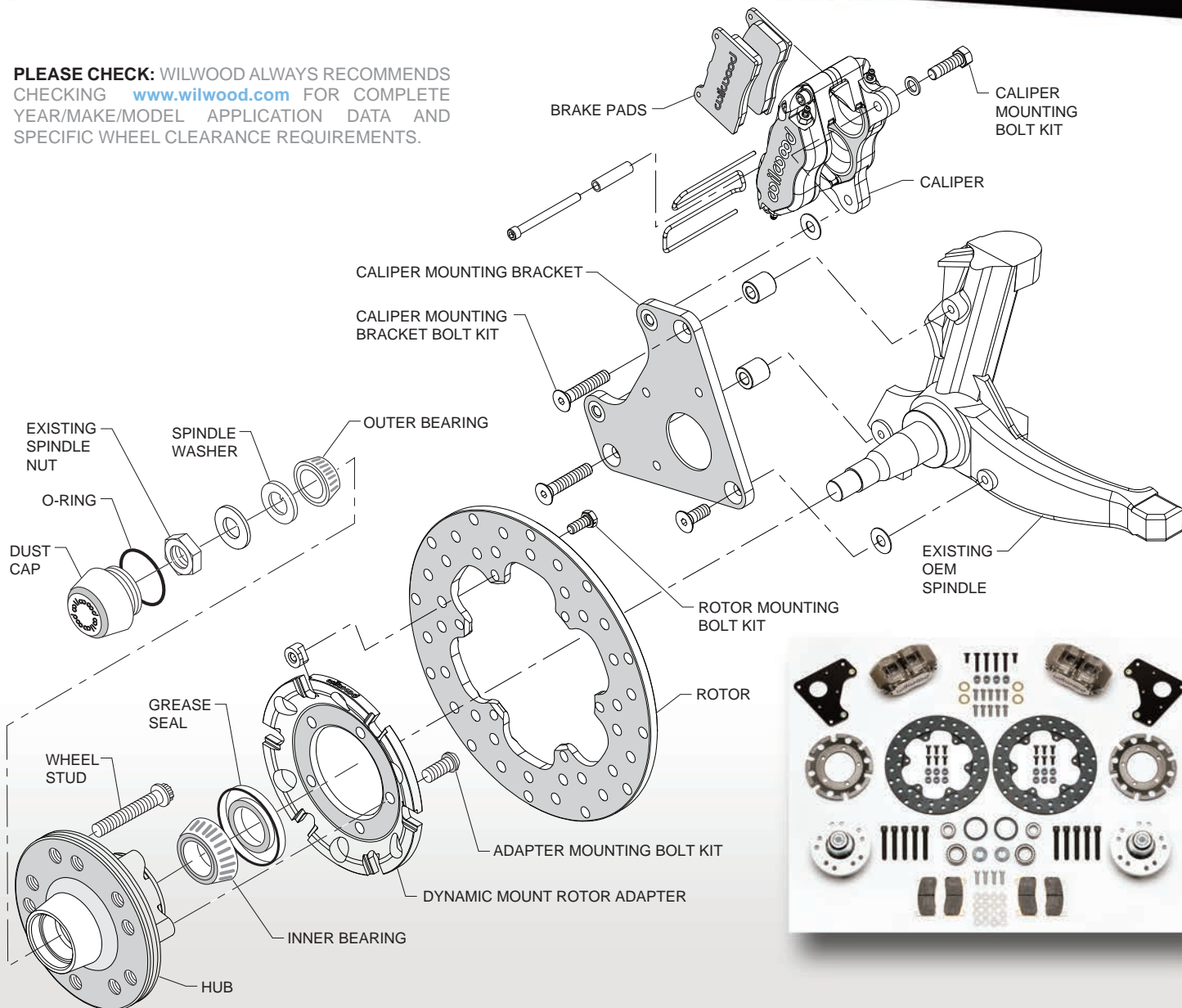

Figure 1. Typical Installation Diagram, 1980-1987 GM "G" Body Shown

ORDERING INFORMATION: DynaPro Front Drag Race Kit with Dynamic Mount 10.75" Rotor

PART NUMBER	DESCRIPTION	CALIPER FINISH
140-14416-DN	1971-1980 Pinto / 1974-1978 Mustang II	Quick-Silver Nickel
140-14417-DN	1967- 1969 Camaro / 1964-1972 Chevelle / 1964-1966 Chevy II / 1976-1974 Nova, Drum Spindle	Quick-Silver Nickel
140-14418-DN	1970-1978 Camaro, Disc Spindle	Quick-Silver Nickel
140-14419-DN	1980-1987 GM "G" Body, Disc Spindle	Quick-Silver Nickel
140-14420-DN	1987-1993 Mustang, Disc Spindle	Quick-Silver Nickel
140-14421-DN	1982-1992 Camaro / Firebird, Disc Spindle	Quick-Silver Nickel
140-14422-DN	1962-1972 MOPAR "B" Body, 1970-1972 MOPAR "E" Body, Drum Spindle	Quick-Silver Nickel
140-14423-DN	1979-1981 Camaro / Firebird, Disc Spindle	Quick-Silver Nickel